

# NOVA

**Operation and Maintenance Manual**

Electric Hydraulic Pump NOVA

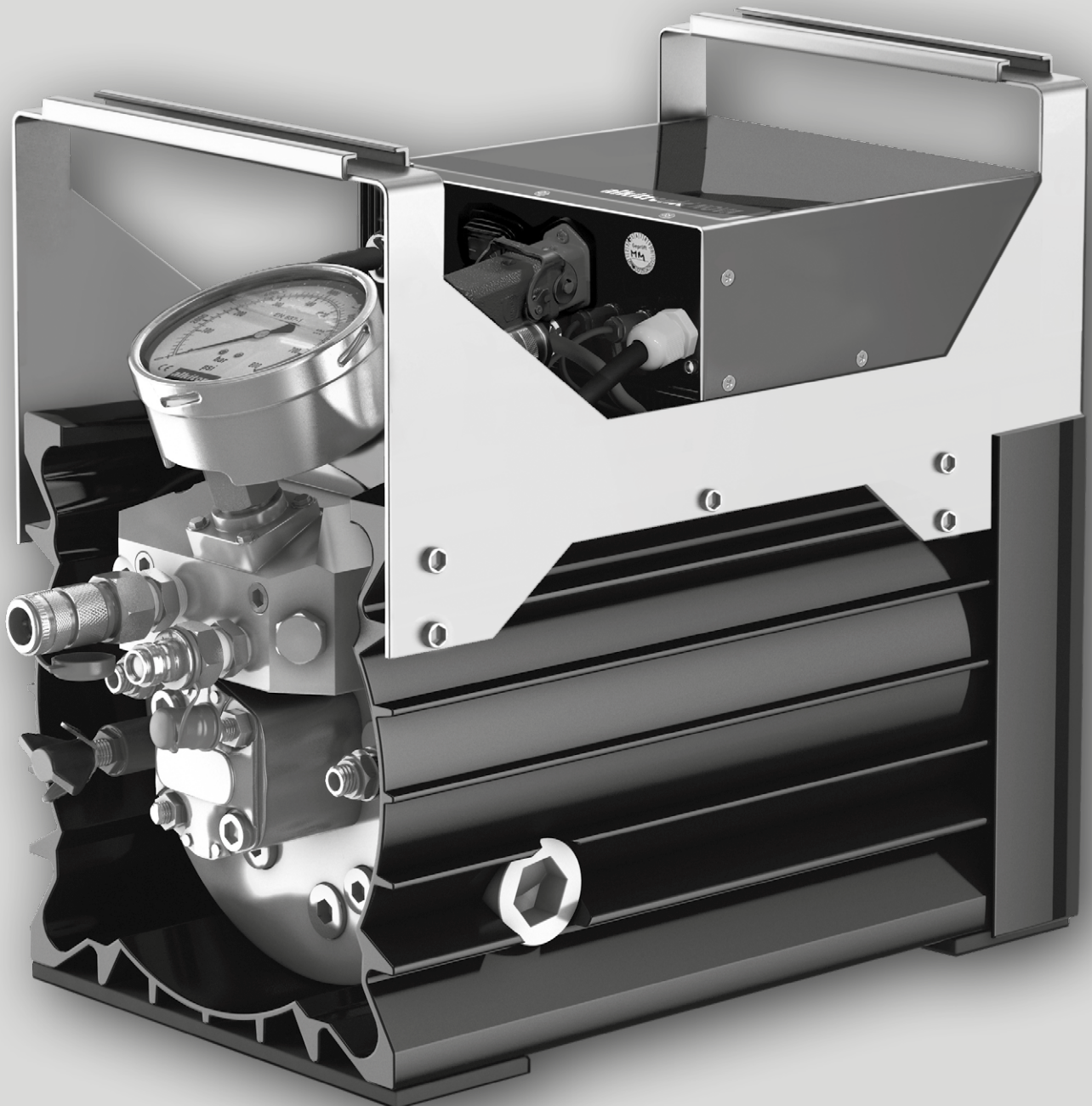

# Operation and Maintenance Manual

## Foreword

Congratulations on your purchase of an *alkitronic*<sup>®</sup> *NOVA* Hydraulic Power Unit! This product sets the highest international standards for quality and safety. To maintain these standards, please read and follow the information and instructions found in the operation and maintenance manual.

Maintenance and repair of the *alkitronic*<sup>®</sup> *NOVA* Hydraulic Power Unit must be performed by alki TECHNIK GmbH or certified workshops trained and instructed by alki TECHNIK GmbH.

Improper maintenance may endanger you and damage the unit. Non-compliance with any of the above items voids all warranty claims!

The operation and maintenance manual contains all basic information and instructions. The operator must read, understand, and observe this material together with the basic precautions before either using or attempting to maintain the *alkitronic*<sup>®</sup> *NOVA* Hydraulic Power Unit. The manual must always be available on site.

This operation and maintenance manual applies only to the *alkitronic*<sup>®</sup> *NOVA* Hydraulic Power Unit. Observe the "Safety information" found in section 2, and all other special instructions in other sections.

## Definition of Symbols



Safety instructions.  
Non-compliance may result in personal injury or death.



Safety instructions.  
Non-compliance may result in damage to the *alkitronic*<sup>®</sup> *NOVA* Hydraulic Power Unit, its functions, or the environment.



IMPORTANT! Information for proper and safe operation.



NOTE! Practical advice and information to make work easier.

## Content

	page
A	<b>Reception Control / Packaging</b> 4
B	<b>General Description</b> 4
<hr/>	
1.	<b>Technical Data / Specifications</b> 4
<hr/>	
2.	<b>Safety Information</b> 4
2.1	Intended use 4
2.2	Operator responsibilities 4
2.3	Possible risks 5
2.4	General electrical and mechanical risks 5
<hr/>	
3.	<b>Starting Procedure</b> 6
3.1	Checking oil level 6
3.2	Connecting to load circuit 6
3.3	Connecting remote control 6
3.4	Important Operating Instructions 6
3.5	Functional test 6
<hr/>	
4.	<b>Operation</b> 7
4.1	Torque adjustment 7
4.2	Remote control 7
4.2.1	Manual operation 7
4.2.2	Automatic operation 7
<hr/>	
5.	<b>Inspections and Maintenance</b> 8
5.1	Visual inspection 8
5.2	Tightness and contamination 8
5.3	Inspection of pressure gauge 8
5.4	Expert inspection 8
<hr/>	
6.	<b>Maintenance</b> 8
6.1	Checking oil level 8
6.2	Adding oil 8
6.3	Draining oil 8
6.4	Filling oil 9
<hr/>	
7.	<b>After Operation</b> 10
7.1	Storage 10
<hr/>	
8.	<b>Technical information</b> 10
8.1	Working pressure 10
8.2	Automatic temperature shut-off 10
<hr/>	
9.	<b>Optional Configuration <i>alkitronic</i><sup>®</sup> <i>NOVA DUO</i></b> 10
<hr/>	
10.	<b>Hydraulic Connections</b> 10
<hr/>	
11.	<b>Troubleshooting Guide</b> 12
<hr/>	
12.	<b>Appendix</b> 13
12.1	Connections 1-hose system 13
12.2	Connections 2-hose system 14
12.3	Replacing the power cord plug 15

# alkitronic® NOVA electrical hydraulic pump

## alkitronic® NOVA

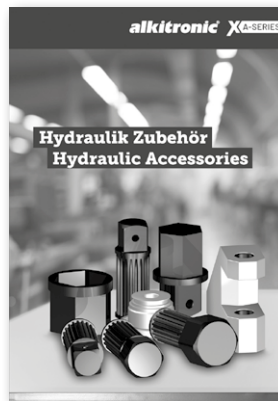
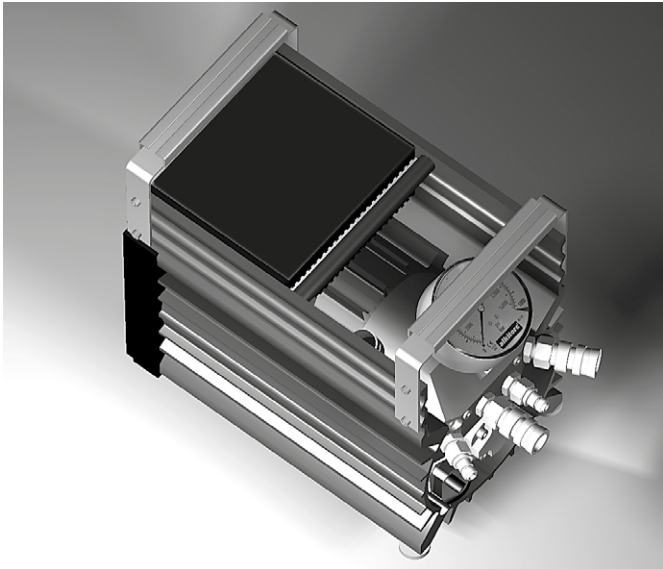

### alkitronic® Accessories

Due to the specific selection of a wide range of accessories, you have a broader work application field.

When you need specific, individual solutions, your **alkitronic® Partner** or alki TECHNIK GmbH will gladly advise you.

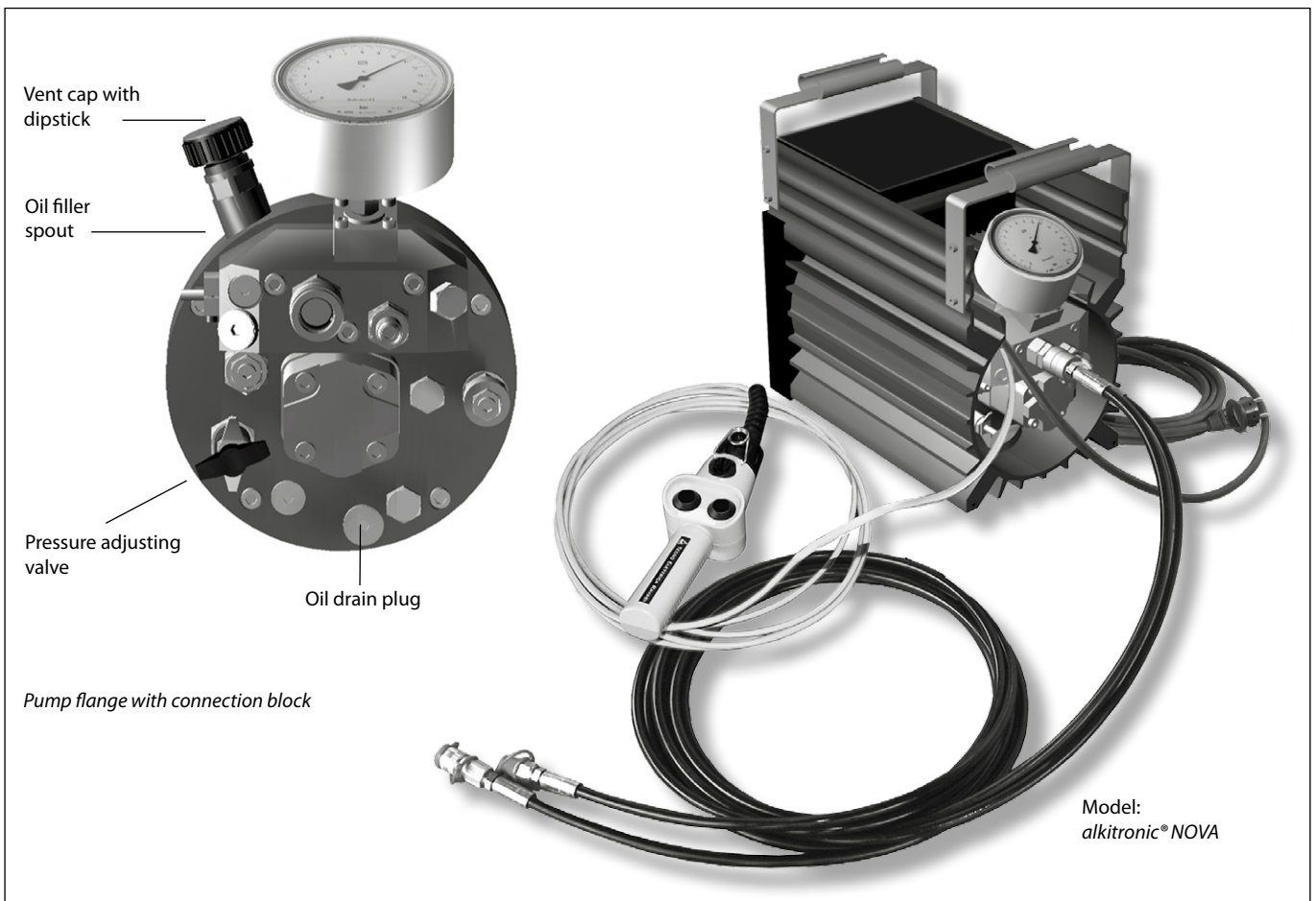

# Operation and Maintenance Manual

## A Reception Control / Packaging



Inspect all components for possible damage. If shipping damage is found, notify the forwarding agent immediately. Return components in the original package to avoid additional damage. Therefore, please keep the packaging.

Portable case includes:

**alkitronic® NOVA** Hydraulic Power Unit, 5 m (16 ft) high-pressure hydraulic hoses, FB Nova remote control.

## B General Description

The Hydraulic Power Unit is designed for one-hose and two-hose operation. To switch from power stroke to return stroke, change the rotational direction of the motor – without use of solenoid valves! Gear / radial piston pumps, driven by a frequency controlled synchronous motor, generate hydraulic pressure, which is transferred through hydraulic hoses into the load circuit. The **alkitronic® NOVA** Hydraulic Power Unit has been especially designed for hydraulic tools with cylinders / pistons, which activate a lever to generate a corresponding torque.

## 1. Technical Data / Specifications

Power source:	Electric motor
Supply voltage:	100 - 253 V / 45 - 66 Hz
Net power*:	2.0 kW
Protection:	IP 54

### Flow rates at 110V

LP range:	12 l/min at 70 bar (732 cu.in./min at 1,015 psi)
HP range 1:	8 l/min at 180 bar (488 cu.in./min at 2,030 psi)
HP range 2:	1.2 l/min at 700 bar (73 cu.in./min at 10,000 psi)

### Flow rates at 230V

LP range:	15 l/min at 70 bar (915 cu.in./min at 1,015 psi)
HP range 1:	10 l/min at 180 bar (610 cu.in./min at 2,030 psi)
HP range 2:	1.5 l/min at 700 bar (91 cu.in./min at 10,000 psi)

Tank capacity:	3.9 l (238 in <sup>3</sup> )
Total weight:	28.5 kg (62.8 lbs) approx.
Outside dimensions:	L 350 x W 220 x H 300 mm (L 14 x W 9 x H 12 inch)
Ambient Temperature:	-20° C to +50° C (-4° F to +122° F)
Hydraulic oil type:	HLP 46 (ask for information about other oil types as well as biodegradable oil)

\*Depending on working pressure, the power consumption of the electric motor may temporarily increase up to 3.5 kW.

## Emission

Continuous sound pressure level  $L_{pA}$  measured at net power (2,0 kW): **< 85 dB(A)**. Measurement according to DIN 45635, Part 11 and ISO 3744.



Supply and return pressures are factory adjusted. For individual adjustments ask the manufacturer.

## 2. Safety Information

### 2.1 Intended use

The **alkitronic® NOVA** electric driven Hydraulic Power Unit may only be used for hydraulic cylinders operating with a single-acting or double-acting hydraulic system and rated for working pressures of min. 700 bar (10,000 psi).

Only use the hydraulic oil listed in the technical data section. All hydraulic connections must be rated for working pressures of min. 700 bar (10,000 psi).

**Do not use the Hydraulic Power Unit for any purpose other than its intended use.**

### 2.2 Operators responsibilities

The operator must have read and understood the instructions in this operation and maintenance manual before using or servicing the **alkitronic® NOVA** Hydraulic Power Unit. Minimum age of the operator must be 18 years.

Operation and service may not be performed, if the concerned person does not understand the purpose, consequences, and precise performance of each procedure. For questions regarding the safety measures and areas of application, your **alkitronic® Partner** will be pleased to assist you.



Improper operation, incorrect application, abuse or use by unqualified personnel may be hazardous to other persons, operator, Hydraulic Power Unit and other property.



The operator is responsible to third parties within the work area.



The **alkitronic® NOVA** Hydraulic Power Unit must not be used in explosion-endangered areas. For operation outdoors or in humid rooms, observe the relevant regulations.

The Hydraulic Power Unit must be protected from moisture. In case of damage to the unit, harnesses or the electric connections, stop operating the **alkitronic® NOVA** Hydraulic Power Unit.



Non-authorized alterations and modifications of the **alkitronic® NOVA** Hydraulic Power Unit are not permitted.

Adjustment screws (S1 and S2, Fig. 1) or bolted connections (S) must not be turned or loosened. The bolted connections are protected by thread locker or sealing wire. Destruction of the sealing will lead to loss of warranty.

# alkitronic® NOVA electrical hydraulic pump



Abb. 1

## 2.3 Possible risks with hydraulic hoses and hydraulic couplings

Correct hose connections see page 10-11 and page 13, Appendix

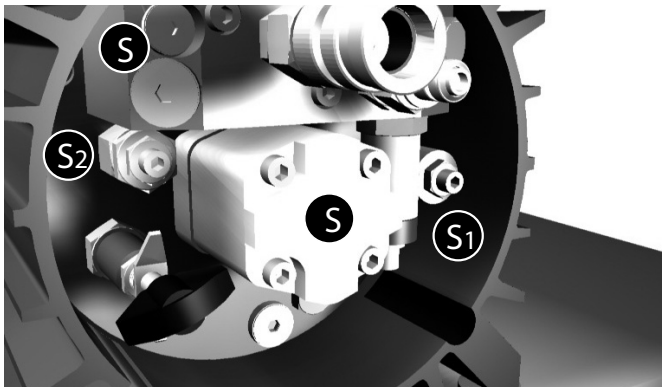

### Hazards due to hose failure & oil leakage

Hose assemblies may fail abruptly and unexpectedly for a variety of reasons. Hydraulic oil shooting out at high pressure and/or at high speed can cause serious personal injury, severe damage to objects, and environmental pollution.



### Examples of potential hazards

- Bursting hose components
- Whipping hose ends
- Oil spray leakage
- Coupling blow-off



### Make sure that:

The design and operation of tools and machines complies with the existing safety regulations. Inspect hose assemblies for damage and wear at regular intervals; if possible, before each use. Inspect hose sets in unpressurised condition; use implements when necessary. Defective or damaged hose assemblies must be replaced immediately. Do not attempt to repair them. Always use new components.



### Never try to locate a leak with your hands!

If leakage occurs, shut down the hydraulic pump immediately. Never try to locate the leak with any part of the body when the hose set is pressurised. Use a suitable implement to inspect the hose for damage.



To avoid hydraulic oil escaping under high pressure, make sure all hydraulic hoses (coupling and nipple) are properly connected and secured with the **alkitronic® NOVA** and the load (motor, cylinder or torque wrench).



### Do not mix **alkitronic®** products with substitute copies!

The interface between the coupling and the nipple is crucial. **alkitronics** unique tolerances and precision must not be tampered with. An improper solution caused by using non-**alkitronic** devices, may lead to an incorrect connection, or even worse an accidental disconnection which results in hydraulic oil shooting out at high pressure.



### Do not extend hydraulic hoses without intermediate coupling.

Reversing the couplers for extension results in reverse flow and reverse control of the hydraulic tool. Non-compliance with these regulations may lead to faulty functions and damage to the tool or serious injuries to the operator.



### A fluid injection injury must always be treated as a medical emergency that requires prompt and accurate diagnosis and treatment.



Possible leaking oil is hazardous to the environment. It must be safely collected and properly disposed of.

## 2.4 General electrical and mechanical risks



The **alkitronic® NOVA** may only be operated, if the power supply matches the electric performance specifications of the unit and all hydraulic connections to the load (motor, cylinder or hydraulic torque wrench) are tight and non-reversible. The load should comply with the minimum requirements for safe operation.



In case of damage and repair, the hydraulic pump must be separated from the power supply and immediately be checked by a qualified technician for electrical safety and mechanical defects. All safety and mechanical defects must be resolved before resuming operation.



In case of a power failure or malfunction, shut-off the hydraulic pump immediately via the power switch, separate the pump from the power supply and put the torque wrench in a safe position.



To avoid the risk of tilting or falling, the **alkitronic® NOVA** must always be set-up securely. When working in high places, it should be secured.

# Operation and Maintenance Manual

## 3. Starting Procedure



Place the **alkitronic® NOVA** Hydraulic Power Unit on firm, level ground. Keep heat exits unobstructed. Covers, foils, or other materials will cause dangerous heat accumulation. Keep the back cover at a distance of at least 50 cm (9.7 in) from walls or other objects.



Before start-up, clean hydraulic hoses and nipples/couplings. Check for damage and possible need for replacement. Place hydraulic hoses flat on the ground. The hoses must not be bent, twisted, stepped on, driven over or mechanically damaged. Contamination of or damage to the hydraulic system may lead to malfunctions or operational failure.

### 3.1 Checking oil level

Refer to step 6.1 „Checking oil level“ and 6.2 „Adding oil“!

### 3.2 Connecting to load circuit

Connect hydraulic hoses to load circuit (V) and to the **alkitronic® NOVA** Hydraulic Power Unit.

All nipples and couplings must be connected completely and securely to avoid hydraulic oil leakage and ensure undisturbed oil flow.

The hydraulic hoses (two-hose system) are provided with paired quick-lock couplings and nipples, to connect Supply/Advance (A) and Return (R) to the head and rod end of the hydraulic torque wrench cylinder (Fig. 3)

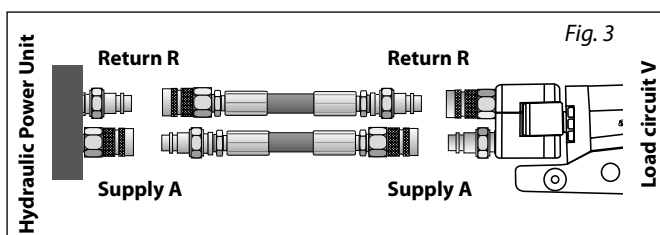

An interruption on the return line will cause excessive overpressure on the rod end of the hydraulic cylinder, which may destroy motor, cylinder or hydraulic torque wrench and cause serious personal injury.



Also refer to the instructions for the appropriate hydraulic torque wrench.

### 3.3 Connecting remote control

**FB NOVA** remote control is connected to socket (Fig. 4, item F).

## 3.4 Important Operating Instructions



An internal self-test is carried out each time the power is switched on (Fig. 4, item N).

**It takes about 5 seconds. Then the NOVA pump is ready for operation.**



**Do not press any key during the self-test** (remote control Fig. 5). If one or both keys are pressed, the pump cannot start! The pump will start again, only after pressing a button.

### Security features:

If an error occurs during operation, e.g. due to current peaks, over-temperature of the unit, or the electronics, the pump switches off.



**Measures:** Power switch off (1) - after about 5 seconds, switch on again and wait for the self test. Then press a button to start the pump. If the pump still does not start, there may be a temperature error. After a short cooling time, the pump is ready for use again. Start the pump via the remote control.



### Note:

In case of any error, the pump will switch to a safe state and try to correct the error by self-test. If the pump still does not start, switch off the pump with the power switch (1), remove power connection, and perform troubleshooting.

Otherwise your **alkitronic® Partner** or the alki TECHNIK GmbH will gladly assist you.

## 3.5 Functional test



Before starting the tightening procedure, run a functional test on the **alkitronic® NOVA** Hydraulic Power Unit applying a maximum working pressure of 100 bar.

Carry out the functional test as shown in Fig. 4:

- Connect Hydraulic Power Unit to the power supply.
- Press power switch (N).
- Turn lock (R) of pressure adjusting valve (2) counter-clockwise.
- Press and hold button (M). Simultaneously turn pressure adjusting valve (2) until a working pressure of 100 bar is indicated on gauge (1).
- Release button (M). Turn lock (R) of pressure adjusting valve clockwise to hold the valve in position (anti-twist protection).
- Press and release button (M) repeatedly to check the system for function and leakages.

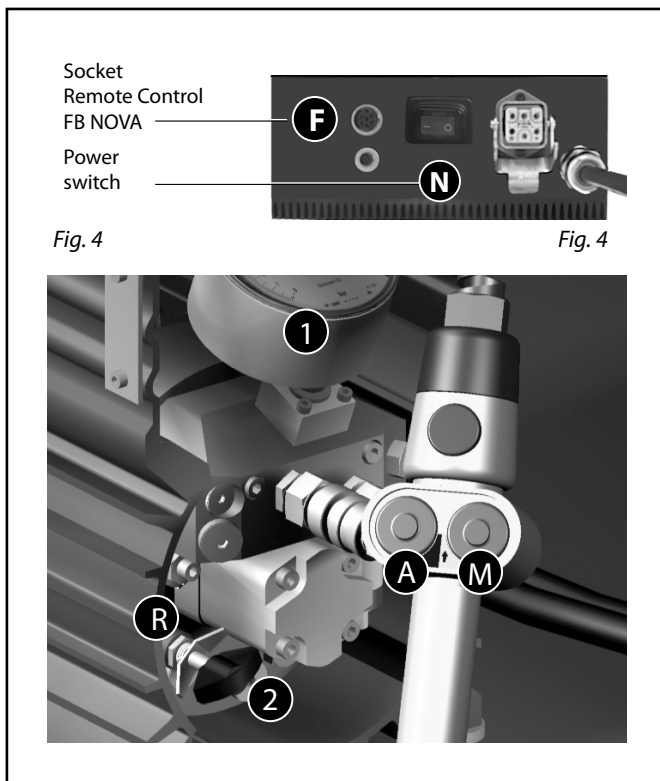

## 4. Operation

The following description applies to the operation of hydraulic torque wrenches.

### 4.1 Torque adjustment (Fig. 4)

- Connect Hydraulic Power Unit to the power supply.
- Switch on power switch (N), wait for self-test.
- Turn lock (R) of pressure adjusting valve (2) counter-clockwise.
- Press and hold button (M). Simultaneously turn pressure adjusting valve (2) until the working pressure in accordance with torque table of the tool is indicated on gauge (1).
- Release button (M). Turn lock (R) of pressure adjusting valve (2) clockwise (anti-twist protection).

### 4.2 Remote Control

- Button (M) for manual operation
- Button (A) for automatic operation



Fig. 5

### 4.2.1 Manual operation (Fig. 5)

- Switch on the pump (N), wait for self-test.
- Torque setting according to section 4.1.
- Press and release button (M) repeatedly to trigger a rotating movement of the hydraulic torque wrench drive.
- Press button (M) repeatedly, until the hydraulic wrench stops rotating and the pressure gauge (Fig. 4, item 1) indicates, that the set working pressure or torque has been reached.



NOTE!

If the hydraulic torque wrench stops rotating, the hydraulic piston may be at the stop limit. Press the button (M) once or twice again! This will ensure that the applied torque has been transferred to the bolted connection.



IMPORTANT!

As soon as the hydraulic piston of the torque wrench stops, release button (M). This avoids an overload of the motor, leading to a possible safety-related shut-down.

### 4.2.2 Automatic operation (Fig. 5)

- Switch on the pump (N), wait for self-test.
- Torque setting according to step 4.1
- Press and hold button (A) for automatic operation of the **FB NOVA** remote control. The wrenching process will start. The correct working pressure or torque has been reached, as soon as the hydraulic torque wrench stops rotating.
- Finally release button (A) after repeated build-up of the set working pressure.



NOTE!

If the hydraulic torque wrench stops rotating, the hydraulic piston may be at the stop limit. Press the button (M) once or twice again! This will ensure that the applied torque has been transferred to the bolted connection.



CAUTION!

#### Observe the safety function!

If button (A) in automatic operation, or button (M) in manual operation, is being released during the wrenching process, the piston rod of the hydraulic cylinder retracts. The **alkitronic® NOVA** Hydraulic Power Unit will shut-off after approximately 3-5 seconds. When the button is pressed once more, the unit will switch on again.

# Operation and Maintenance Manual

## 5. Inspections and Maintenance

### 5.1 Visual inspection

First inspect the system for proper connections (Fig. 3).

### 5.2 Tightness and contamination



High-pressure hydraulic hoses and all couplings, nipples, fittings and connections must be checked for damage and possibly replaced or cleaned. Contamination in the hydraulic system will cause malfunctions and operating failure. Check hydraulic components for tightness. Defective components must be professionally replaced.

### 5.3 Inspection of pressure gauge



To ensure the torque precision, inspect the electronic and the precision of the gauge (Fig. 4, item 1) by testing the gauge. This inspection must be performed at least once a year.

In case of damage, authorized personnel must immediately inspect the *alkitronic*<sup>®</sup> *NOVA* Hydraulic Power Unit for electrical safety and mechanical defects. Otherwise a mechanical and electrical safety inspection is recommended once a year.

### 5.4 Expert inspection

According to legal regulations a mechanical and electrical safety inspection once a year is required.



For safety reasons all hydraulic hoses used for regular requirements must be replaced at the latest after five years (additional max. two years storage). For increased requirements (multiple shift operation, short cycle times, hand tools) replace the hoses after two years.

Hydraulic hoses should be stored in cool, dry, free from dust conditions. Avoid direct sunlight, UV-radiation and storing temperatures below -10°C (+14°F). Hose ends and connections must be sealed.

## 6. Maintenance



Before starting any maintenance work, the *alkitronic*<sup>®</sup> *NOVA* Hydraulic Power Unit must be disconnected from the power supply (pull power cord plug).

Repairs may only be performed by authorized personnel.

The Hydraulic Power Unit does not require any special maintenance. However, the oil level in the tank must be checked regularly.

By frequent use of the *alkitronic*<sup>®</sup> *NOVA* Hydraulic Power Unit a yearly oil change is recommended. For proper oil type refer to section 1 "Technical information".

### 6.1 Checking oil level

Place the Hydraulic Power Unit horizontally on level ground. Remove dipstick (1) and clean it with a lint-free cloth. Screw the dipstick in again. After renewed unscrewing, check if the oil level is within the recommended range. Use the two markings max and min. If the oil level is within the range of max and min, the level is fine. If the level is below min, add oil (Fig. 6).

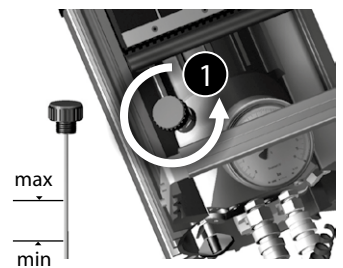

Fig. 6

### 6.2 Adding oil

Place a funnel in the oil filler spout (1) and add a sufficient quantity of hydraulic oil "HLP 46".

Clean the housing of oil. Cleaning material and oil residue must be properly disposed of (Fig. 7).

Install dipstick (1) in clockwise direction (Fig. 7).

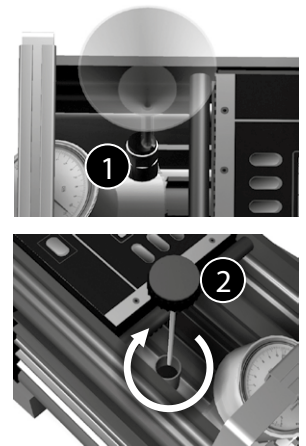

Fig. 7

### 6.3 Draining Oil

For draining, place an approx. 5 cm (2 in) high wooden block (1), or similar, beneath the vent-side of the Hydraulic Power Unit, so that the oil in the unit will flow towards the lowest point. Collect leaking oil by placing a drain pan (2) underneath. Open and remove oil drain plug (3) by turning it counter-clockwise with an 8 mm hex head wrench. To speed-up the



# alkitronic® NOVA electrical hydraulic pump

draining process, remove the dipstick (Fig. 8, item 4).

After the oil has been drained, remove oil residues from the housing.

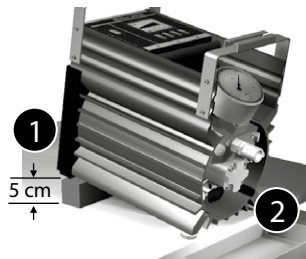
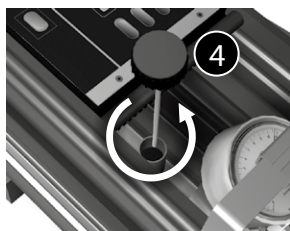
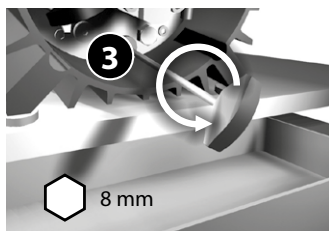

Fig. 8

Fig. 8



In case of storage or longer system downtime, the tank must always be filled sufficiently (dipstick check – oil level between max and min).



Used hydraulic oil and oil deposits must be properly disposed of. Hydraulic oil may not enter the ground or be poured into drains. Hydraulic fluid spills must be wiped up by suitable material immediately.

## 6.4 Filling oil

Carefully place the Hydraulic Power Unit in an upright position (1), so that the vent is at the bottom and the unit flange on the top. During fill-up, the air must be able to escape from the tank through the oil drain plug (2). Remove dipstick (Fig. 9).

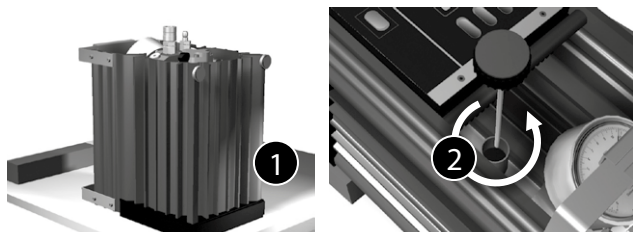

Fig. 9

Place a funnel (1) in the oil filler spout (2) and add 3.9 liters (238 in<sup>3</sup>) of hydraulic oil „HLP 46“ with a measuring jug. Pour in the oil slowly to avoid bottle-neck in the funnel. Since the funnel cannot be sealed in the opening, oil leakage might occur. After the filling process, remove the funnel and close the oil drain plug (3) by turning it clockwise with an 8 mm

hex head wrench. Recommended torque: 35 Nm (25.8 ft.lbs). Return the Hydraulic Power Unit carefully to the horizontal position and install dipstick (4) in clockwise direction (Fig. 10).

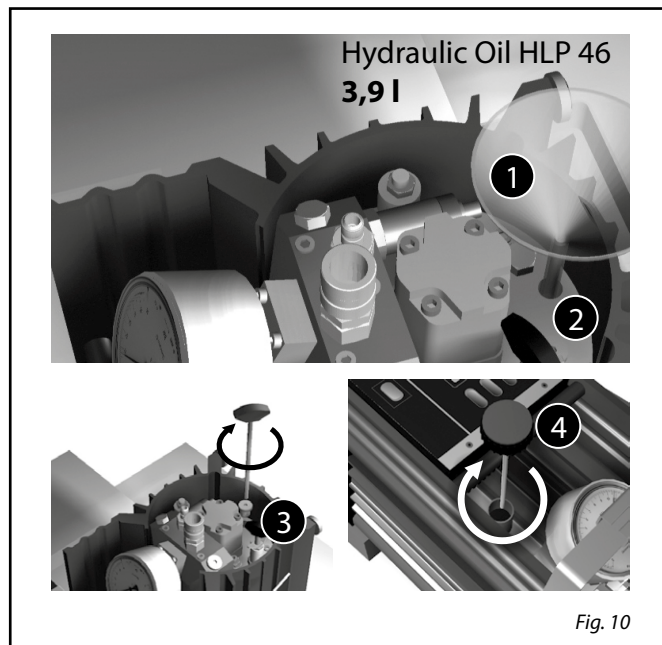

Fig. 10



Finally, check the oil level with the dipstick once more and add oil if necessary (refer to steps 6.1 and 6.2).

After the oil has been filled, remove oil residue from the housing.

# Operation and Maintenance Manual

## 7. After Operation

**IMPORTANT!** After finishing the operation with the *alkitronic*<sup>®</sup> **NOVA** Hydraulic Power Unit, disconnect the system from the mains. Store it in a dry, clean place. Remove hydraulic hoses and hydraulic wrench. Also read the following.

### 7.1 Storage

Always store the dry, clean **NOVA** Hydraulic Power Unit in the *alkitronic*<sup>®</sup> transportation case or in any lockable box.

Moisture leads to oxidation on both housing and interior parts. As a result malfunction and further damages may occur.

#### Hydraulic hoses

- IMPORTANT!**
- For storage, make sure the hydraulic hoses are disconnected and that the ends of the hose lines and the connecting components (couplings/nipples) are plugged with protecting caps.
  - Store the hydraulic hoses in a cool, dry, and dust-free location.
  - Avoid direct solar and UV radiation, ozone-generating lighting (i.e. fluorescent sources of light, mercury vapor lamps), and storage temperatures below - 10°C (+14°F).
  - Hydraulic hoses must not come into contact with acids, lyes, or solvents.
  - Store hoses stress-free and flat. When stored in circles, observe the minimum bend radius specified by the manufacturer.

**IMPORTANT!** Temperatures between +15°C (+59°F) and +25°C (+77°F), a relative humidity under 65% are considered favorable storage conditions. Intrusion of ozone or other harmful air components can be prevented by packing in foil.

#### Taking out of operation

**IMPORTANT!** If the **NOVA** Hydraulic Power Unit is stored for a long time, store the cleaned tool in a closeable and dry room, out of the reach of children. Moving tool parts are to be protected against oxidation. Additionally note item 7.1, Storage.

## 8. Technical Information

### 8.1 Working pressure

Recommended working pressure 70 - 700 bar/1,015 - 10,000 psi. Also see item 1.0 Technical Data, page 4, Flow Rates.

### 8.2 Automatic temperature shut-off, see Item 3.4, page 6

**IMPORTANT!** The *alkitronic*<sup>®</sup> **NOVA** Hydraulic Power Unit has an automatic temperature shut-off to protect against excessively high temperatures. Should a high temperature shut-off occur, the unit will be ready to operate again after a short cooling period.

## 9. Optional Configuration *alkitronic*<sup>®</sup> **NOVA DUO**

For simultaneous operation of two hydraulic torque wrenches.

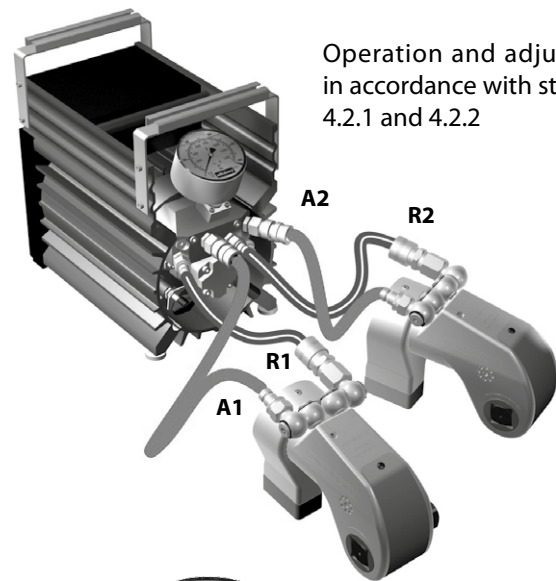

Operation and adjustment in accordance with steps 4.1, 4.2.1 and 4.2.2

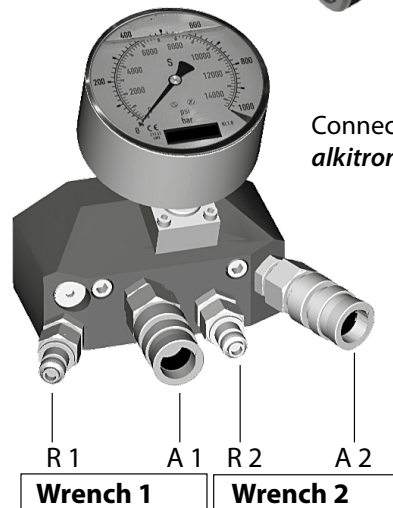

Connection block *alkitronic*<sup>®</sup> **NOVA DUO**

(A = Advance, R = Return)

## 10. Hydraulic Connections

### A - One-hose system

One-hose system for single-acting cylinders.

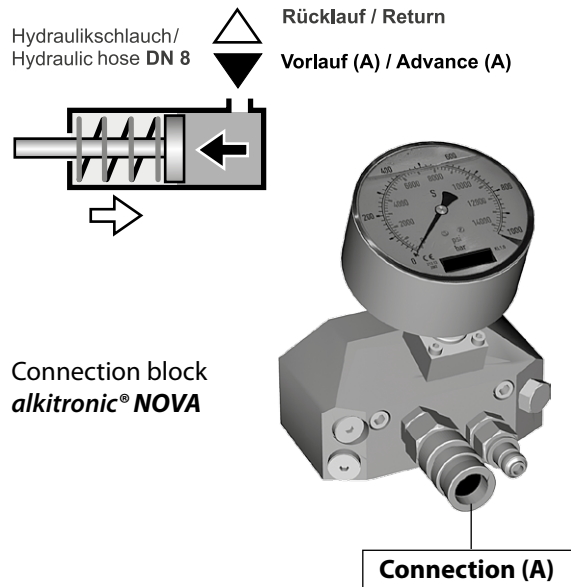

Operation and adjustment in accordance with steps 4.1 and 4.2.1

 The one-hose system can only be operated manually,  
**IMPORTANT!** not in the automatic mode!

### B - Two-hose system

#### Correct Connections:

- Pump
- HD-Hose
- Hydraulic torque wrench

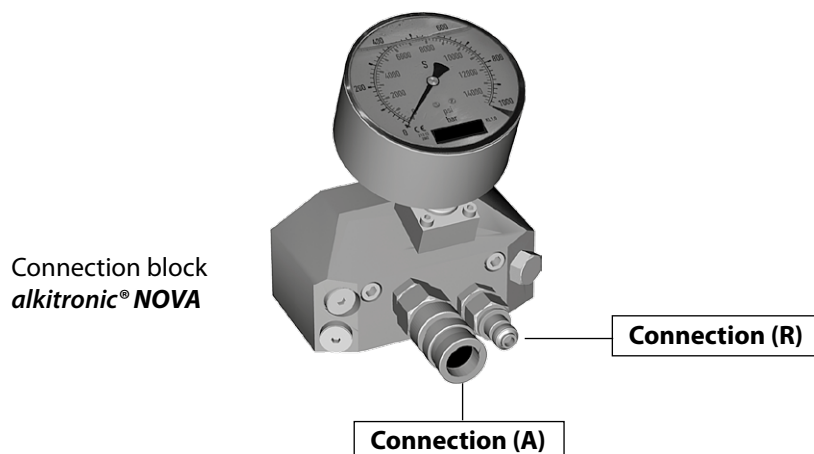
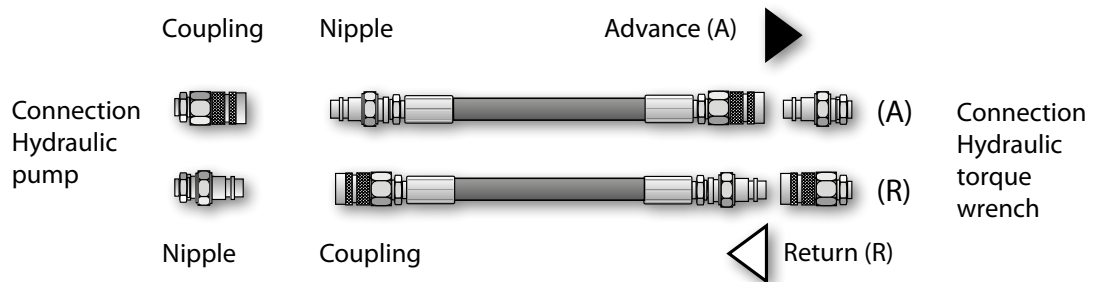

# Operation and Maintenance Manual

## 11. Troubleshooting Guide

Fault description	Possible cause	Remedy
Hydraulic Power Unit inoperative	Faulty socket / plug / power cord	Components to be checked by authorized personnel
Power switch or display (N) not illuminated (Fig. 2a/2b)	Fuses blown Insufficient fused power supply	Install fuses with correct sizing and tripping characteristics
Hydraulic Power Unit inoperative	FB NOVA remote control unplugged	Connect remote control
Power switch or display (N) not illuminated (Fig. 2a/2b)	Faulty connecting cable	Remote control to be checked by alkitronic partner Alternative for NOVA comfort: only use in emergency operation mode
Hydraulic Power Unit inoperative Power switch or display (N) not illuminated (Fig. 2a/2b)	Faulty electronics	alkitronic NOVA to be checked by alkitronic partner
Hydraulic cylinder does not extend or retract	Low hydraulic oil level	Add hydraulic oil
	Misadjusted pressure relief valve (Fig. 4, item 2)	Check and adjust valve
	Defective cylinder sealing	alkitronic NOVA to be checked by alkitronic partner
Hydraulic lines are very hot	Low hydraulic oil level	Add hydraulic oil
	Degraded hydraulic oil quality	Change oil
	Damaged pump	alkitronic NOVA to be checked by alkitronic partner
Hydraulic Power Unit operating - no pressure build-up	Misadjusted pressure relief valve (Fig. 4, item 2)	Check and adjust valve
	Defect pressure relief valve (Fig. 4, item 2)	alkitronic NOVA to be checked by alkitronic partner
	Defective cylinder seal	alkitronic NOVA to be checked by alkitronic partner
Power loss of the Hydraulic Power Unit	Low hydraulic oil level	Add hydraulic oil
Leaking hydraulic cylinder	Defective cylinder sealing	alkitronic NOVA to be checked by alkitronic partner

## 12. Appendix

### 12.1 Connection of one-hose system for single-acting cylinders

**Vorlauf (A) = Hochdruck 700 bar max. !**  
**Supply (A) = high pressure 700 bar max. !**

**alkitronic®- Anschlüsse an Hydraulikpumpe**  
**Connections to hydraulic power unit**  
**Ref.-Nr. Bezeichnung / description**

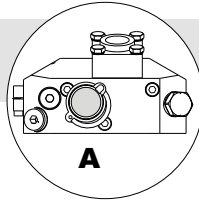

**20322** Doppelnippel /  
 Double fitting NPT 3/8"- 3/8"

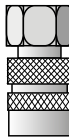

**20314** Kupplung / Coupling IG (female thread) NPT 3/8"

**alkitronic®- Hydraulikschlauchanschlüsse**  
**Connections to hydraulic hose**  
**Ref.-Nr. Bezeichnung / description**

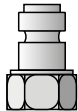

**20315** Nippel / Nipple IG (female thread) NPT 3/8"

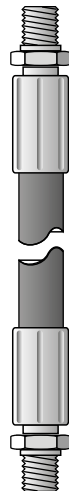

**71012** HD-Schlauch **DN 8**  
 kompl. mit Kupplung u. Nippel (5 m)  
 High-pressure hose **DN 8**  
 compl. with coupling and nipple (5 m)

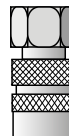

**20314** Kupplung / Coupling IG (female thread) NPT 3/8"

**alkitronic®- Anschluss am Hydraulikschrauber /**  
**Connection to hydraulic torque wrench**  
**Beschreibung / Description**

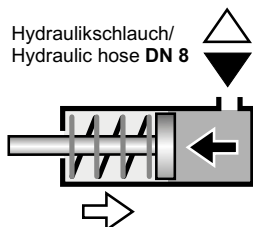

Hydraulikschlauch/  
 Hydraulic hose **DN 8**

▲ Rücklauf (R) / Return (R)

▼ Vorlauf (A) / Supply (A)

# Operation and Maintenance Manual

## 12.2 Connection of two-hose system for double-acting cylinders

**Vorlauf (A) = Hochdruck 700 bar max. !  
Supply (A) = high pressure 700 bar max. !**

**Rücklauf (R) = Niederdruck 100 bar max. !  
Return (R) = low pressure 100 bar max. !**

**alkitorc®- Anschlüsse an Hydraulikpumpe  
Connections to hydraulic power unit  
Ref.-Nr. Bezeichnung / description**

**alkitorc®- Anschlüsse an Hydraulikpumpe  
Connections to hydraulic power unit  
Ref.-Nr. Bezeichnung / description**

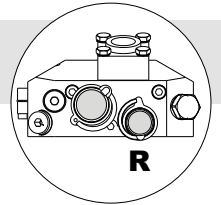
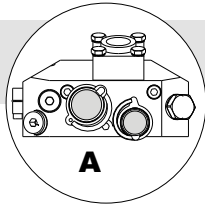

**20322** Doppelnippel /  
Double fitting NPT 3/8"- 3/8"



**20322** Doppelnippel /  
Double fitting NPT 3/8"- 3/8"

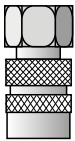

**20314** Kupplung / Coupling IG (female thread) NPT 3/8"

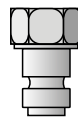

**20315** Nippel / Nipple IG (female thread) NPT 3/8"

**alkitorc®- Hydraulikschlauchanschlüsse  
Connections to hydraulic hose  
Ref.-Nr. Bezeichnung / description**

**alkitorc®- Hydraulikschlauchanschlüsse  
Connections to hydraulic hose  
Ref.-Nr. Bezeichnung / description**



**Hochdruck-Hydraulikschlauch-Set / High-pressure hose kit**

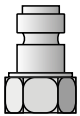

**20315** Nippel / Nipple IG (female thread) NPT 3/8"

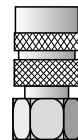

**20314** Kupplung / Coupling IG (female thread) NPT 3/8"

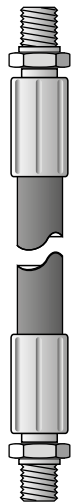

**71012** HD-Schlauch **DN 8**  
kompl. mit Kupplung u. Nippel (5 m)  
High-pressure hose **DN 8**  
compl. with coupling and nipple (5 m)

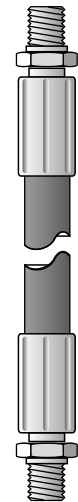

**71012** HD-Schlauch **DN 8**  
kompl. mit Kupplung u. Nippel (5 m)  
High-pressure hose **DN 8**  
compl. with coupling and nipple (5 m)

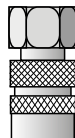

**20314** Kupplung / Coupling IG (female thread) NPT 3/8"

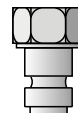

**20315** Nippel / Nipple IG (female thread) NPT 3/8"

**alkitorc®- Anschluss am Hydraulikschrauber /  
Connections to hydraulic torque wrench  
Beschreibung / Description**

**alkitorc®- Anschluss am Hydraulikschrauber /  
Connections to hydraulic torque wrench  
Beschreibung / Description**

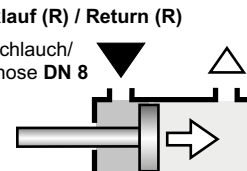
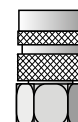
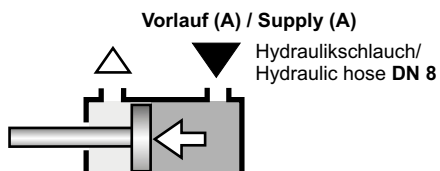
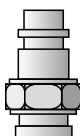

# alkitronic® NOVA electrical hydraulic pump

## 12.3 Replacing the power cord plug



CAUTION!

Only authorized personnel may replace the power cord plug.

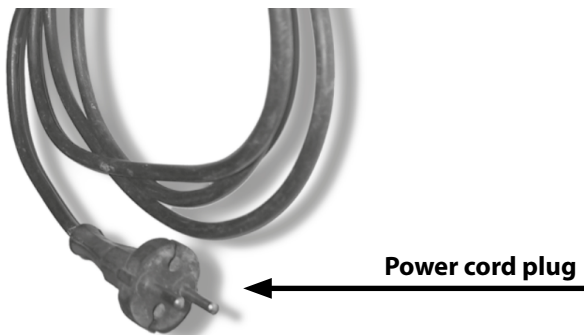

### Procedure:

1. Disconnect **alkitronic® NOVA** Hydraulic Power Unit from the power supply (pull power cord plug).
2. Separate the plug from the power cord.



IMPORTANT!

All **alkitronic® NOVA** Hydraulic Power Units have a three-wire power cord. Only authorized personnel may replace the power cord plug.

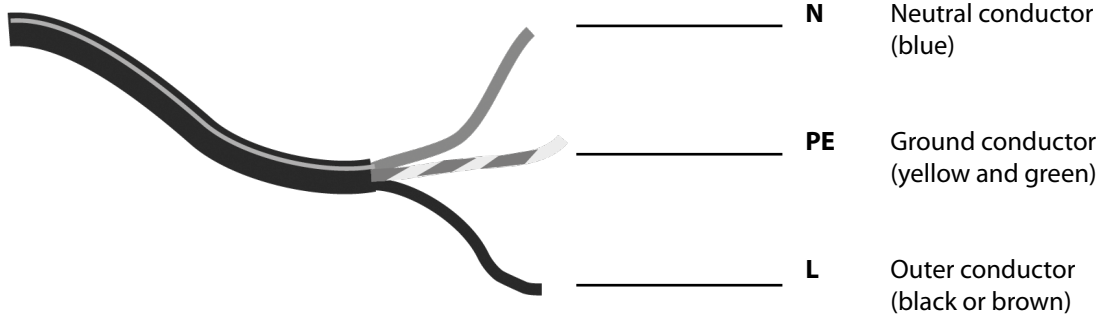

DANGER!

After connecting, perform an electric safety inspection. Metal housing must be grounded! Improper connection may cause electric shock, resulting in personal injury or death.

Materials and specifications are subject to change without notice.

© alki TECHNIK/GBA alkitronic'nova/2/10.10.2023/4p

## YOUR PLUS FOR MORE PERFORMANCE

### Increased quality

Premium production  
Highest quality materials  
Long product life cycles  
Experience in bolting technology since 1984  
Made in Germany – international patents

### Increased precision

Precise, customer-specific torques  
High repeatability  
Reliability in permanent operation  
Documentation of tightening results  
Automatic shut-off

### Increased productivity

Quicker tightening without reworking  
No environmentally caused failures (IP54, ATEX)  
High work safety  
Easy to use: clear, simple instructions  
Low maintenance and cost efficient

### Better service

Technical advice on site  
Training offers  
Manufacturer's calibration and certification  
Lifecycle support  
Spare part and repair service

alki TECHNIK GmbH

Development, Production and Distribution of Bolting Systems

Unterlettenweg 4 – 85051 Ingolstadt/Germany – fon +49 841 97499-0 – fax +49 841 97499-90  
info@alkitronic.com – www.alkitronic.com

### EXTRACT FROM OUR PRODUCT RANGE

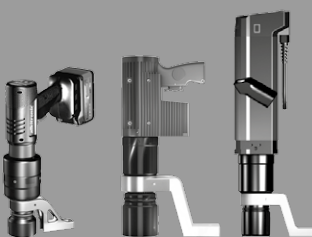

**alkitronic X<sup>E</sup>-SERIES**

THE ELECTRICS

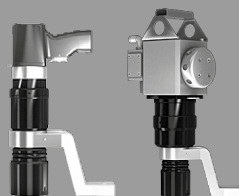

**alkitronic X<sup>P</sup>-SERIES**

THE PNEUMATICS

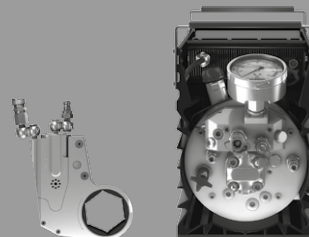

**alkitronic X<sup>H</sup>-SERIES**

THE HYDRAULICS



**alkitronic X<sup>M</sup>-SERIES**

THE MANUALS