



H-AT
H-AX

**Operation and
Maintenance Manual**

Hydraulic Torque Wrench Series H

Operation and Maintenance Manual

Foreword

Congratulations on your purchase of an **alkitronic® Hydraulic Torque Wrench**! This product sets the highest international standards for quality and safety. To maintain these standards, please read and follow the information and instructions found in the operation and maintenance manual.

Maintenance and repair of the **alkitronic® Hydraulic Torque Wrench** must be performed by alki TECHNIK GmbH or certified workshops trained and instructed by alki TECHNIK GmbH.

Improper maintenance may endanger you and damage the unit. Non-compliance with any of the above items voids all warranty claims!

The operation and maintenance manual contains all basic information and instructions. The operator must read, understand, and observe this material together with the basic precautions before either using or attempting to maintain the **alkitronic® Hydraulic Torque Wrench**.

The manual must always be available on site.

This operation and maintenance manual applies only to the **alkitronic® Hydraulic Torque Wrench**. Observe the "Safety information" found in section 2, and all other special instructions in other sections.

Definition of Symbols



Safety instructions.
Non-compliance may result in personal injury or death.



Safety instructions.
Non-compliance may result in damage to the **alkitronic® Hydraulic Torque Wrench**, its functions, or the environment.



IMPORTANT! Information for proper and safe operation.



NOTE! Practical advice and information to make work easier.

Content Table

	Page
A Reception Control and Packaging	3
B General Description	3
B1 Model Description	3
1. Technical Data	5
2. Safety Instructions	5
2.1 Intended use	5
2.2 Operators responsibilities	5
2.3 Possible hazards	5
3. Operation Instructions	5
3.1 Placing tool in operation	5
3.2 <u>Model AT preparing for bolting</u>	6
3.2.1 Finishing with square drive inserts	6
3.2.2 Positioning DMA (reaction arm)	6
3.3 Support of reaction moment / Support points	7
3.4 Replacement AVS Standard Square Drive	7
3.5 <u>Model H-AX preparing for bolting</u>	8
3.5.1 Support of reaction moment / Support points	8
3.5.2 Positioning reaction arm DMA (optional)	9
4. Operation	10
4.1 Connecting hydraulic hoses	10
4.2 Tightening and loosening	10
4.2.1 Safety instructions	10
4.2.2 Starting procedure hydraulic power unit	11
4.2.3 General description tightening/loosening	11
5. Ending or Interrupting the Work	12
6. Functional and Operational Tests	12
6.1 Optical inspection	12
6.2 Tightness and contamination	12
6.3 Specialist inspection	12
7. Service / Storage / Maintenance	12
7.1 Lubrication	12
7.2 Storage	13
7.3 Taking out of operation	13
7.4 Maintenance intervals	13
8. Technical Notes	13
9. Appendix	13
Trouble Shooting	14
Technical Data	15

alkitronic® H-AX / H-AT hydraulic torque wrenches

A Reception Control / Packaging



Inspect all components for possible damage. If shipping damage is found, notify the forwarding agent immediately. Return components in the original package to avoid additional damage. Therefore, please keep the packaging.

B General Description

The *alkitronic® Hydraulic Torque Wrench* with the 2 hydraulic hose system for tightening or loosening of heavy bolt connections. The hydraulic pressure to the Torque Wrench is being converted to a torque via an hydraulic piston. The reaction force can be transmitted to a suitable support point via the insertable reaction absorber (*DMA*) or directly via the housing (model *alkitronic® H-AX*). The torque to the hydraulic pump is determined according to the torque chart. The individually pivoting joint couplings (360°, vertical 180°) are convenient, secur, and reliable.

B 1 Model Descripton

alkitronic® H-AT Hydraulic Torque Wrench up to approx. 72.000 Nm* for threads of M 14 and larger. The one-piece, torsion resistant, ergonomically shaped housing is made of high density aluminium. The setting table for the wide torque range ist directly on the tool. The square drive is easily changed from tightening to loosening.

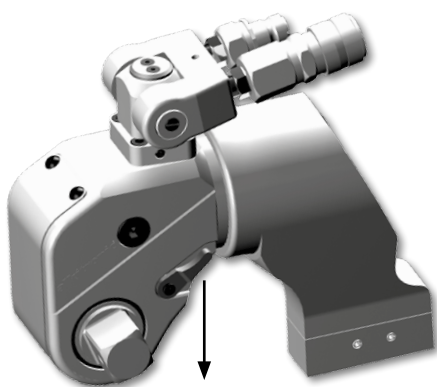

Unclamping:
Push the latch down, the wrench is released. See 4.2.3 Tighten/Loosen description, last paragraph.

* approx. values / torque values are dependent on model

alkitronic® H-AX 2-parts Torque Wrench: up to approx. 49.000 Nm*; developed for applications in restricted space and difficult to access areas; *H-AX* drive unit of heavy-duty material; fast changing of the *H-AX* hexagon link with extremely small housing radius; drive unit with interchangeable hexagon link from 17 to 145 mm.

Trouble-free support without affecting the torque accuracy by lateral force. Drive unit and hexagon link in line, extremely flat and flush design.



Recommendation: *alkitronic®* Hydraulic Pumps

For fast, reliable operation of the *alkitronic® Hydraulic Torque Wrench*, we recommend our *alkitronic® NOVA* or *VELOX* Hydraulic Pumps. Operating pressure max. 700 bar, can be used worldwide in all mains grids (100-253 V / 45-66 Hz). Depending on the model, up to 4 hydraulic wrenches can be operated at the same time. Low running costs, robust and compact design, capable of continuous operation. Without magnetic valve control, the pumps offer high durability equipment and simple automatic operation.

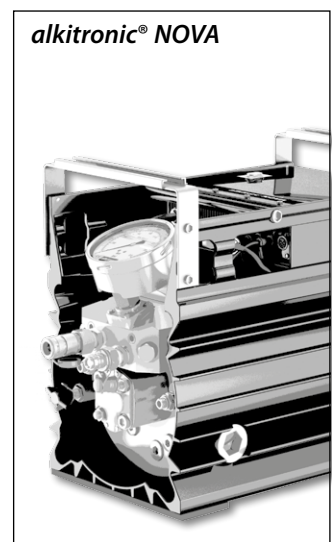
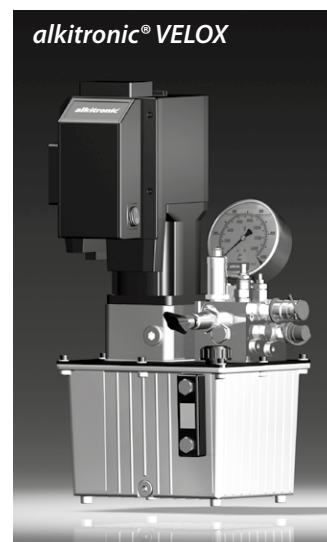

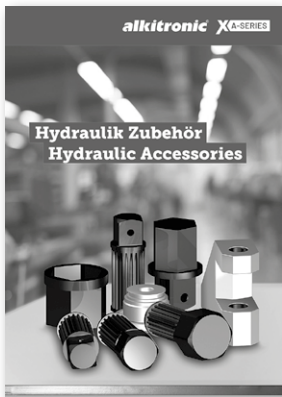

alkitronic® Accessories

Our specific selection of a wide range of accessories, gives you a broader work application field.

When you need specific, individual solutions, your **alkitronic® Partner** or alki TECHNIK GmbH will gladly advise you.

alkitronic® Accessories for H-AT Hydraulic Torque Wrenches

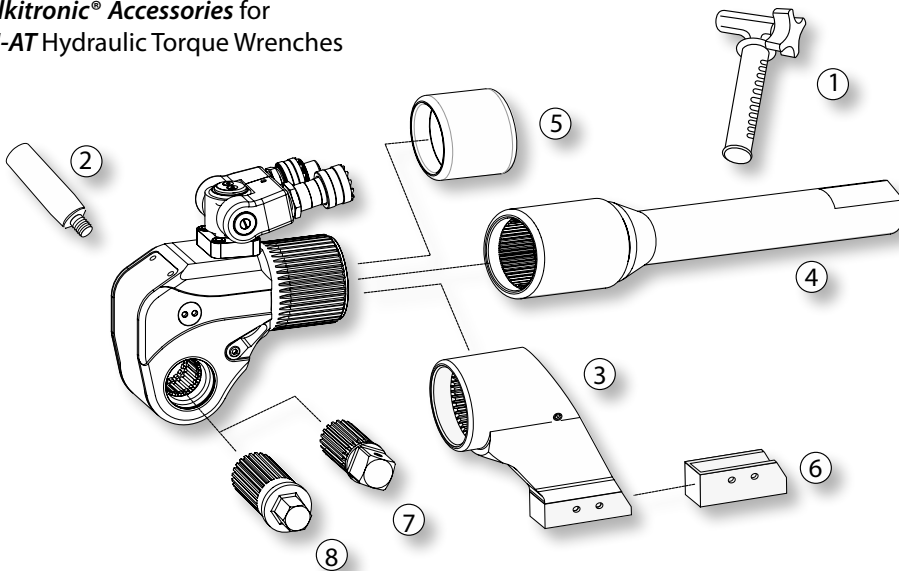

- (1) Carrying handle
 - (2) Handle
 - (3) **DMA** standard reaction arm
 - (4) Pipe extension
 - (5) Reaction sleeve
 - (6) Reaction arm cover (different sizes available upon request)
- alkitronic® H-AT Drive Pins**
- (7) **AVS** square drive pin
 - (8) **AIS** hex drive pin

alkitronic® Accessories for H-AX Convertible Type Torque Wrench

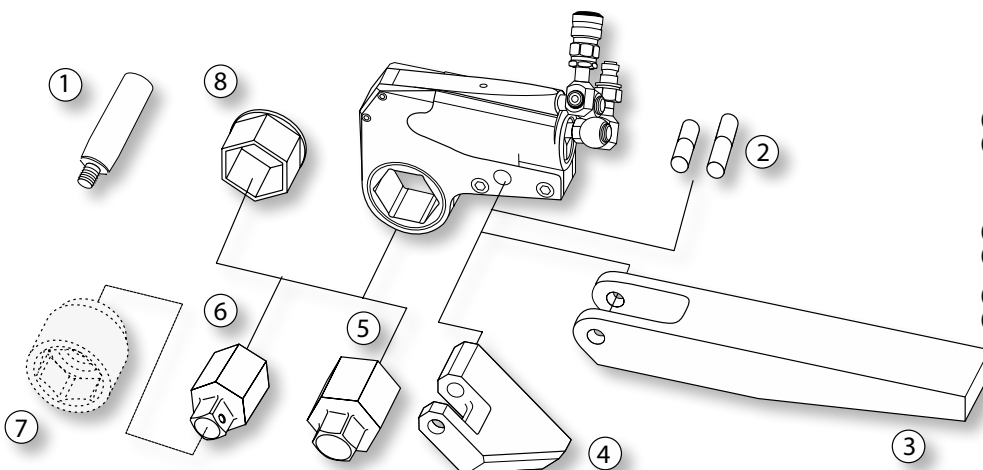

- (1) Handle
 - (2) **Link safety pins**
„short“ standard version,
„long“ to use for additional reaction arms
- DMA** reaction arms
- (3) „extended“ version
 - (3) „low point“ version
- alkitronic® H-AX Drive Inserts**
- STABI**
- (4) Reducer to standard hex drive
 - (5) Reducer to standard square drive
- (7) **STACO** Standard socket
- (8) **STA** Standard adaptor

alkitronic® H-AX / H-AT hydraulic torque wrenches

1. Technical Data

Operation pressure	max. 10,000 psi / 700 bar
Ambient temperature	-20° C to +50° C
Switch-off accuracy	± 3%

2. Safety Instructions

2.1 Intended use

alkitronic® Hydraulic Torque Wrench is designed to tighten or loosen heavy duty bolt connections. Do not use the Torque Wrench for any other purpose.

2.2 Operators responsibilities

The operator must have read and understood the instructions in this operation and maintenance manual before using or servicing the *alkitronic® Hydraulic Torque Wrench*. Minimum age of the operator must be 18 years.

Operation and service may not be performed, if the concerned person does not understand the purpose, consequences, and precise performance of each procedure. For questions regarding the safety measures and areas of application, your *alkitronic® Partner* will be pleased to assist you.



Improper operation, incorrect application, abuse or use by unqualified personnel may be hazardous to other persons, the operator, the Hydraulic Power Unit and other property.



The operator is responsible to third parties within the work area.



For operation outdoors or in humid rooms, observe the relevant regulations. Keep children and bystanders away while operating the tool.



Non-authorized alterations and modifications of the *alkitronic® Hydraulic Torque Wrench* are not permitted.

2.3 Possible hazards



When operating under high hydraulic pressure, any damage to a tool component may lead to fatal injuries. Therefore in case of damage to the tool, connections or the hydraulic hoses, stop operating the Torque Wrench. In case of damage, the Torque Wrench must immediately be inspected by a qualified technician for hydraulic safety and mechanical defects. Repairs may only be performed by authorized personnel. All safety and mechanical defects must be eliminated before resuming operations.



Before starting repairs disconnect the tool from the hydraulic power unit. All hydraulic hoses must be pressure-free.



Leaking oil is hazardous to the environment. Hydraulic oil may not enter the ground or be poured into drains. Hydraulic fluid spills must be wiped up by suitable material immediately.

3. Operation Instructions



The *alkitronic® Hydraulic Torque Wrench* may only be operated if the technical data (see torque chart) matches the hydraulic performance specifications of the hydraulic power unit.



To avoid electric shocks, the *alkitronic® Hydraulic Torque Wrench* and the hydraulic power unit must be grounded.



Working pressure for *alkitronic® Hydraulic Torque Wrenches* and single components may not exceed 700 bar.

Comply with resilience specifications for adapters and attachments to avoid damage to property or personal injury.

3.1 Placing tool in operation

Control and safety inspection

- The drive inserts/adaptors and reaction arms (*DMA*) must be correctly fitted and undamaged. Never use damaged parts under any circumstances!
- Use original *alkitronic®* spare parts only!
- Adapter or socket sizes must correspond exactly to the size of the nut or the screw.
- Couplings, nipples of the Torque Wrench and hydraulic hoses must be connected properly.
- Local regulations for the working environment and for the hydraulic hoses must be complied with.



Special reaction arms, drive inserts or sockets are required for tightening and loosening bolt connections (available as an accessory).



Alterations/replacements or setting up a hydraulic hose connection must always be carried out without hydraulic pressure.

Prepare the joint before connecting or operating the hydraulic power unit!

Operation and Maintenance Manual



IMPORTANT! Always check the Torque Wrench and connections for cleanness and free movement. Insufficient lubrication may significantly affect the torque accuracy. If necessary, clean and slightly grease the joints, gliding surfaces, tothing etc. (see page 12, from item 7.1 Lubrication).

3.2 Preparing for bolting - *alkitronic*[®]H-AT

3.2.1 Finishing with square drive inserts

Example *alkitronic*[®] STACO (standard socket)

- First, prepare the Torque Wrench for the chosen rotating direction (tightening or loosening). Place the *AVS* Standard Square Drive Pin (1) in the chosen position (replacement of the *AVS*, see 3.4). The rotation direction is indicated by the Torque Wrench housing.

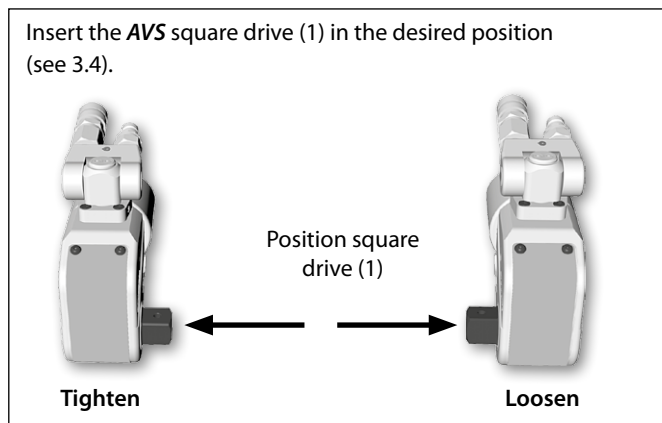

NOTE! For a direction change, the square drive insert is being changed from one side of the Torque Wrench to the other side.

- Next place the *alkitronic*[®] STACO (2) on the square drive. Insert the safety pin and secure it with the rubber ring.

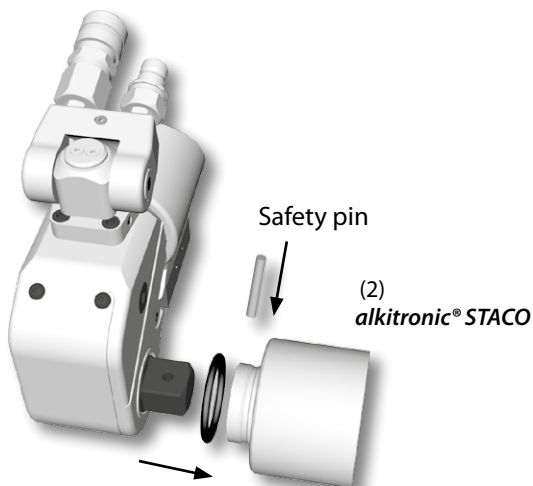

Slide rubber ring over the safety pin.

Fig. 1 - Rotating directions tightening/ loosening

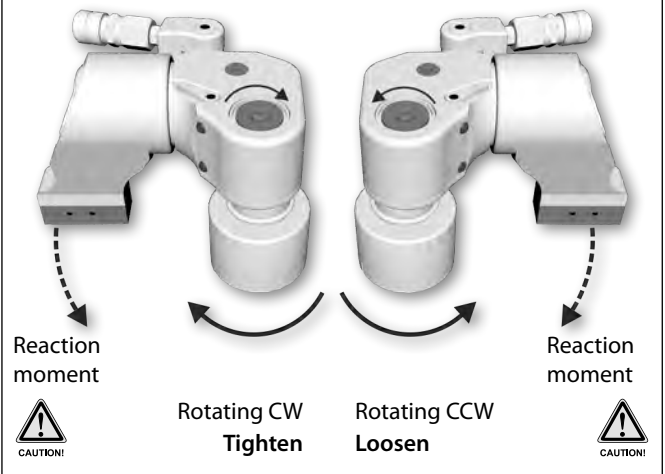

3.2.2 Positioning *DMA* (Reaction arm)

Press the safety button down (3) and remove the *DMA* from the external tothing. Insert the *DMA* completely in the chosen position into the tothing (locking device must be engaged).

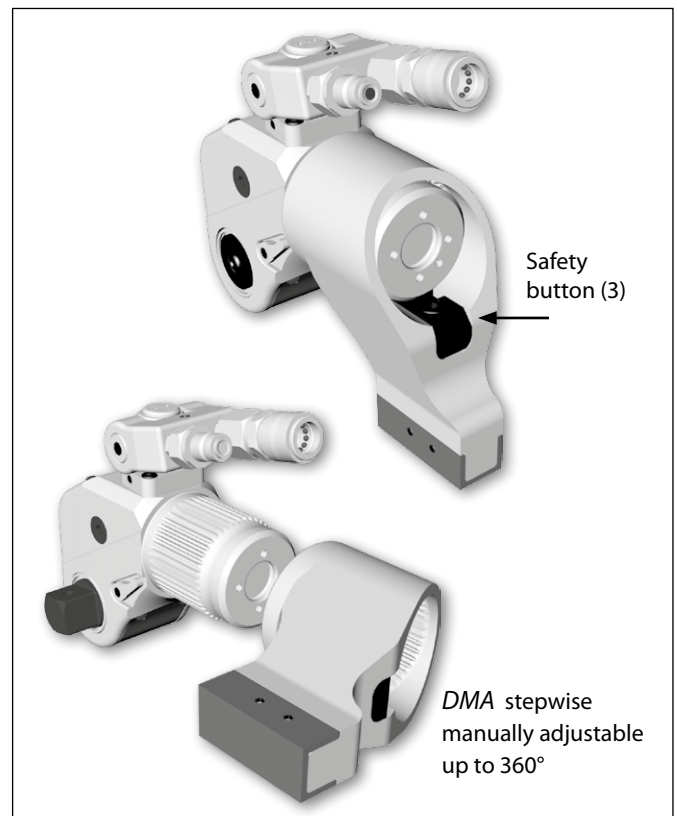

IMPORTANT! Correct positioning of the *alkitronic*[®] *DMA*. See page 7, from item 3.3.

alkitronic® H-AX / H-AT hydraulic torque wrenches

3.3 Support of reaction moment / Support points

Place *DMA* vertical and parallel to the axis of the bolt resp. socket/adaptor.

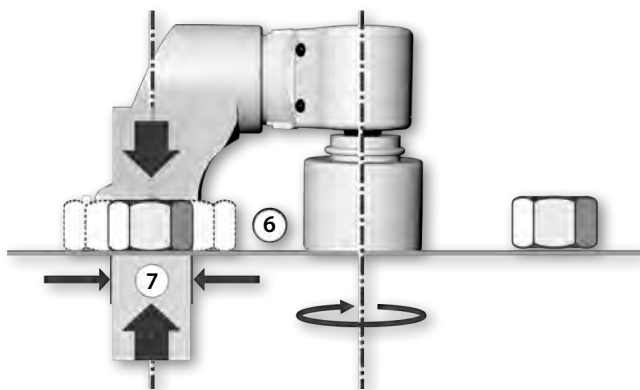
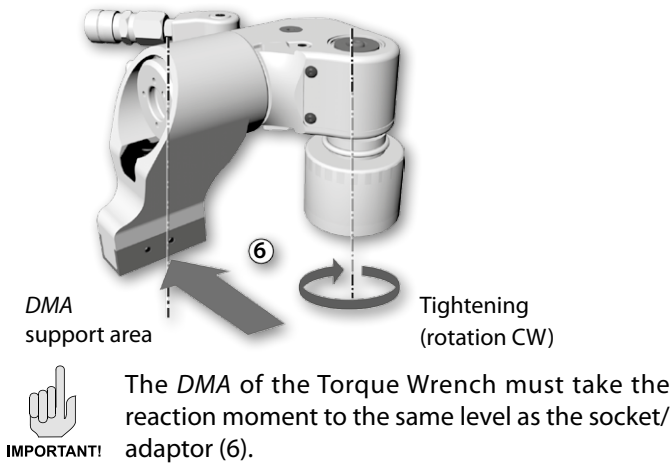
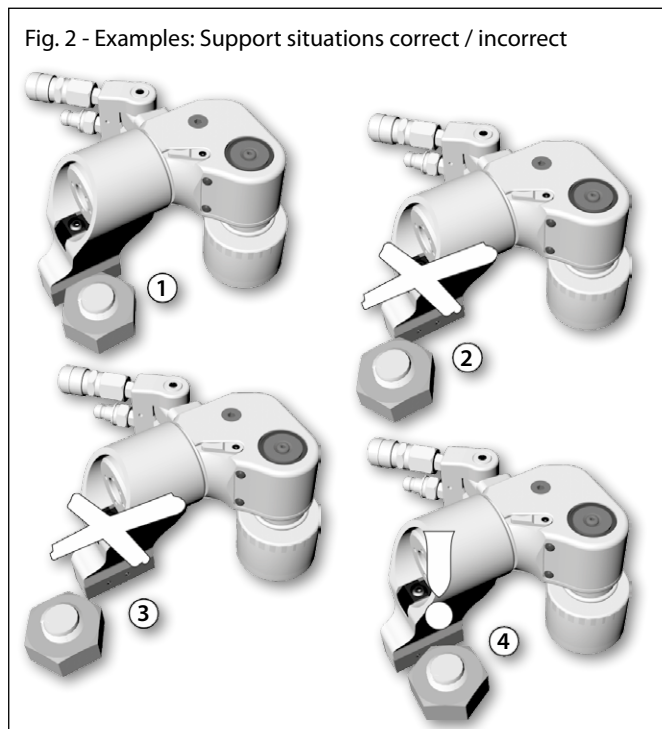

Fig. 2 - Examples: Support situations correct / incorrect



Support correct / incorrect *alkitronic*® H-AT

Fig. 2 - Description support positions

(1) Correct support position



(2) Reaction surface too small and out of the support area.



(3) Tilted reaction support out of the *DMA* support area - high hazard potential - must be strictly avoided!



(4) Sharp-edged counter bearings may cause damages to the *DMA*.



Different levels of the bolting joint and the proper support area can cause dangerous tilting moments. This situation must be strictly avoided. If it occurs, the max. torque of the tool must be reduced. If there are any questions concerning such a situation, please contact your *alkitronic*® Partner or *alki TECHNIK GmbH* for instructions, prior to use..

3.4 Replacement of square drive or other drive inserts

An exchange will be necessary to change the rotating direction or damaged drive inserts (e.g. square drive AVS) with other drive inserts from our accessories program.

Models H-AT: The push button (1) must be pressed to change the drive square.

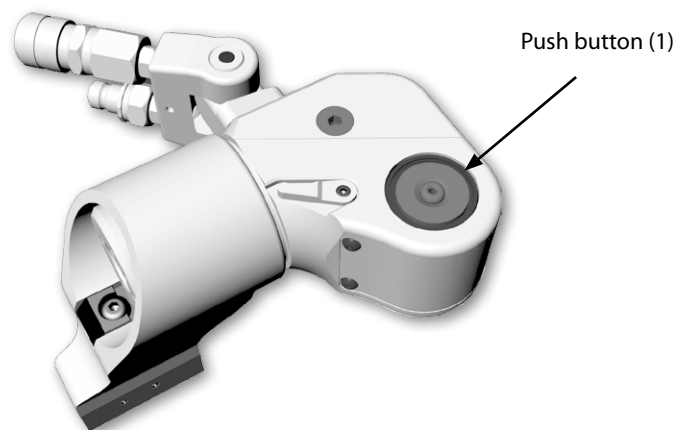

Operation and Maintenance Manual

Procedure:

- Press the push button (1) and hold it down. Pull the square drive (2) out of the housing. Remove the push button.
- After the exchange, put it together in the reverse order and secure the square drive (2) with the push button (1) again.
- Check that the push button is firmly connected to the insert.

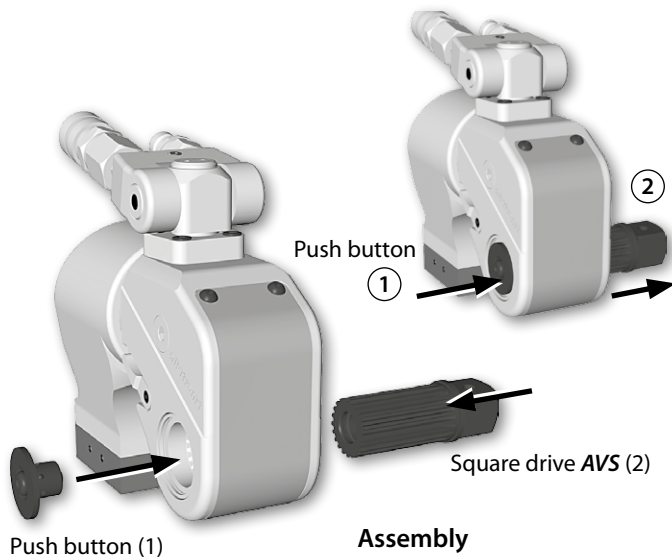

After replacements, check inserts or adapters are properly secured. Otherwise serious personal injuries or damage to the tool may occur.

3.5 Preparing for bolting - *alkitronic*® H-AX

Assembling the *alkitronic*® H-AX

- Select the *H-AX hexagon link* (1) corresponding to the joint. Make sure the hexagon link is suitable for the drive unit (2). Do not use the hexagon links of any other tools.
- Push the *H-AX drive unit* without twisting into the hexagon link up to the stop. By inserting the standard link bolt (3) completely both parts of the tool are firmly connected and secured.

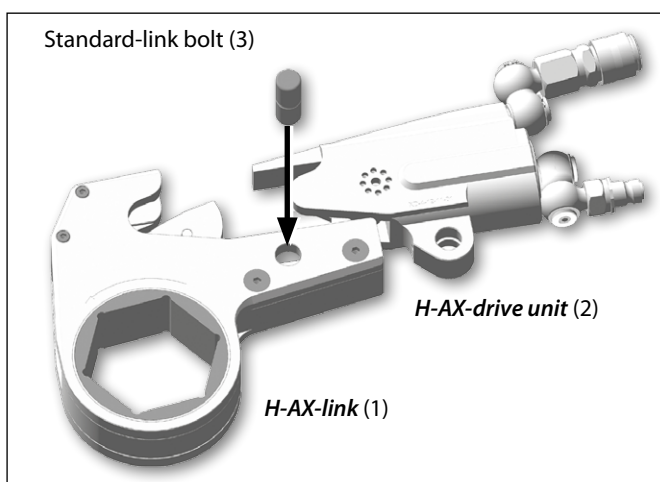

Changing the hexagon link

- Remove the link bolt (3) and pull the drive unit out (2) from the hexagon link.
- Assembly as described above.

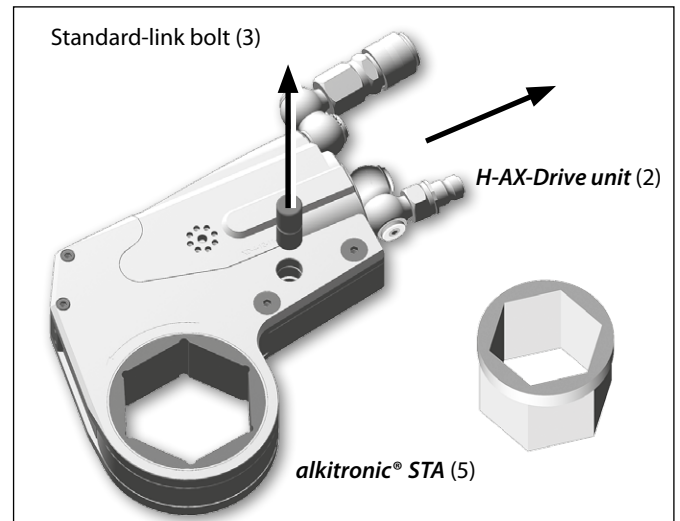

NOTE! To reduce the spanner width, an optional *alkitronic*® STA (5) can be used in the hexagon link drive.

Setting the rotation (tightening/loosening)

- The rotation is changed by reversing the *alkitronic*® H-AX Torque Wrench by 180°. The bolting direction is marked at the housing of the hexagon link.

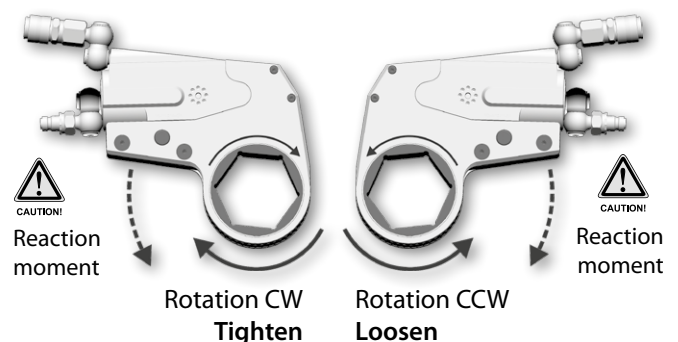

3.5.1 Support of reaction moment / Support points



A safe and stable counter mounting is essential. Improper support may lead to damage to the tool or injury to the operator due to high reaction forces generating from the tool.

Place the reaction surface (1) of the *H-AX hexagon link* (Fig. 3) against an adjacent nut, flange or solid system component.

alkitronic® H-AX / H-AT hydraulic torque wrenches

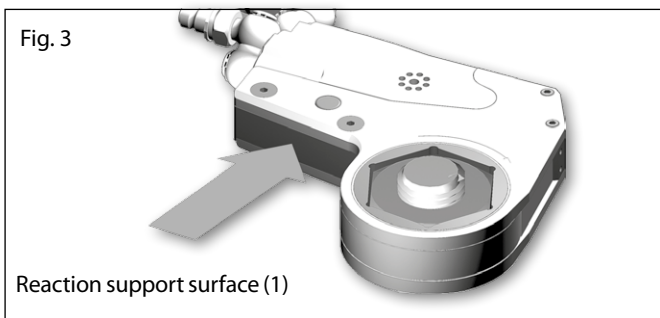

Support position correct/incorrect alkitronic® H-AX.
Description of supports Fig. 4:

(1) Correct support!



(2) Reaction surface too small and out of the support area.



(3) Tilted reaction support out of the support area - high hazard potential - must be strictly avoided!



(4) Punctual loadings or sharp-edged counter mountings may cause damages to the housing.

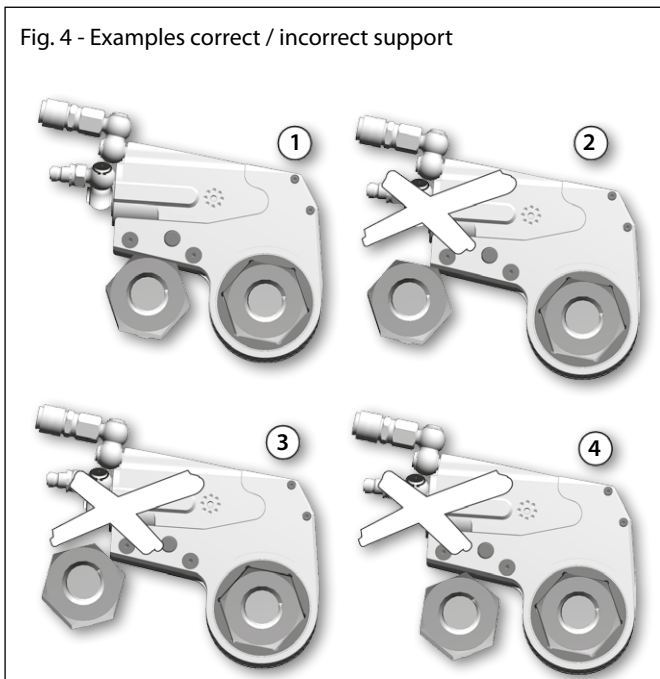

Dangerous tipping can be caused by the bolting connection and Torque Wrench being at different heights. For this situation, reduce the maximum torque of the wrench. Before starting work, ask your **alkitronic® Partner** or **alki TECHNIK GmbH** for safe solutions.

3.5.2 Positioning the DMA - alkitronic® H-AX (option)

Depress the short standard link bolt (3) and insert the DMA (6) correctly. Then attach the longer link bolt (7) to secure the DMA with the H-AX drive unit and the H-AX hexagon link.

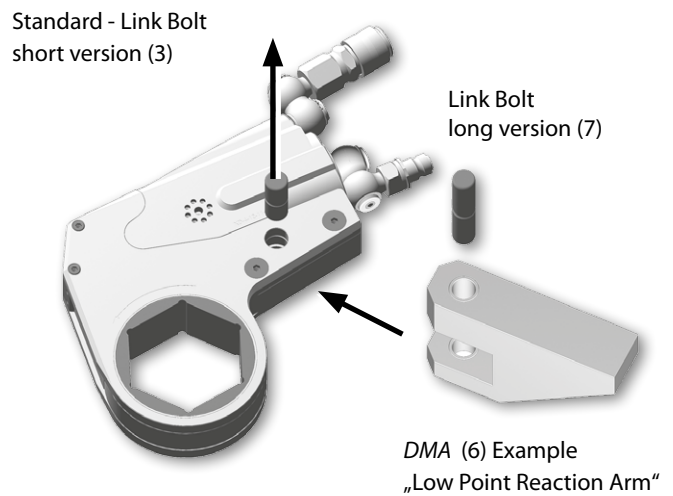

Professional positioning of the **alkitronic® DMA** is dependent on the joint.

Also see Fig. 4 - correct/incorrect support points.

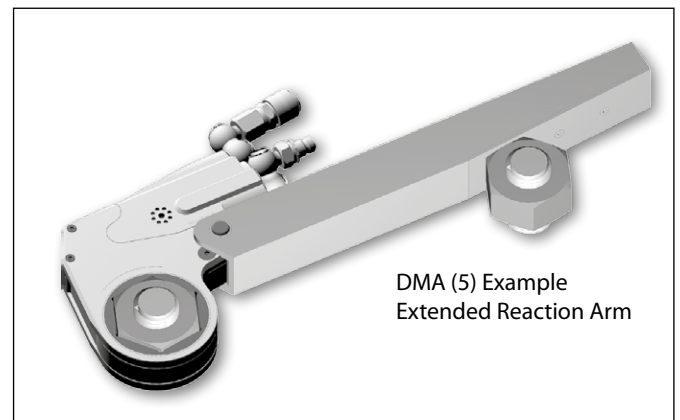

Depending on the application a DMA - Extended Reaction Arm (5) - can also be used.

4. Operation

4.1 Connecting hydraulic hoses

The nipple at the two-hose-system is the connection for Advance (A). The coupling is the connection for Return (R). Original **alkitronic**® hoses, couplings and hydraulic power units are designed to guarantee a correct connection.

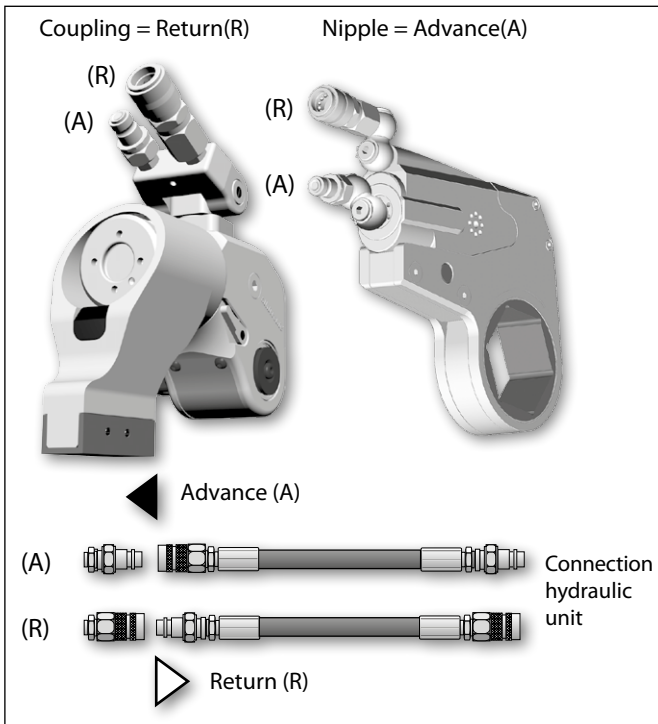

Do not lift or carry the **alkitronic**® Hydraulic Torque Wrench by the hoses. Before start-up, clean hoses and nipples/couplings. Check for damage and possible need for replacement. Place hydraulic hoses flat on the ground. The hoses must not be bent, twisted, stepped on, driven over or mechanically damaged.

Contamination of or damage to the hydraulic system may lead to malfunctions or operational failure.



Inspect Torque Wrench and hose assemblies for damage and wear at regular intervals. If possible, before each use. Inspect hose sets in unpressurised condition. Use implements when necessary. Defective or damaged hose assemblies must be replaced immediately. Do not attempt to repair them. Always use new components.



To avoid hydraulic oil escaping under high pressure, make sure all hydraulic hoses (coupling and nipple) are properly connected and secured with the Hydraulic Pump and the load (motor, cylinder or Torque Wrench).

Do not make improper modifications of the hy-

draulic hoses/couplers. Interchanging quick-lock couplings will reverse the flow direction and the control of the load. Non-compliance with these regulations may lead to faulty functions and damage to the tool or serious injuries to the operator.

4.2 Tightening and loosening

4.2.1 Safety instructions



Comply with all applicable local and safety regulations when putting the tool in operation.



Inspect and test all components for damage. Do not operate with damaged parts!
Keep clearance for the hoses, swivel and couplings.



Do not operate the **alkitronic**® Hydraulic Torque Wrench unattended under any circumstances. A rapid "switch off" in case of emergency must always be ensured.



Maintain a safety distance. If a bolt rotates freely, the tool or the bolts may be ejected uncontrollably from the threaded connection and may cause life-threatening injuries.

Beware of free rotating drive parts. Always keep clothing, jewellery, long hair, and cables away from moving parts.



Do not touch the DMA, moving parts, or the hoses during operation!

The DMA support must always be safe and stable to ensure correct reaction support.



For individual solutions your **alkitronic**® Partner will be pleased to assist you.



Always place drive inserts or adaptors (e.g. **STABI**, **STACO**, **STA**) completely on bolt/nut and keep the drive in axis line to the bolt during the bolting process.

- Improper tool operation or incorrect reaction support may cause:



- strain breakage in adaptors, housing or drive elements,
- faulty torque transmission,
- bruises or even life-threatening injuries (parts splintering off).

- Non-compliance with any above items will void all warranty claims.

alkitronic® H-AX / H-AT hydraulic torque wrenches

Danger areas:



Never place your hand or fingers between the *DMA* and support point or under the housing of the *H-AX Torque Wrench*. High risks of injuries.



Identification of danger points

alkitronic® H-AX

Tightening (rotation CW)



Reaction moment

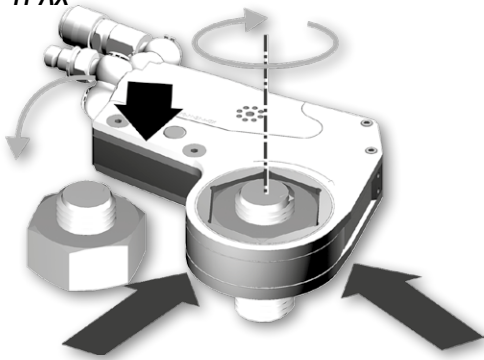

Tightening (rotation CW)

alkitronic® H-AT



Reactionsmoment

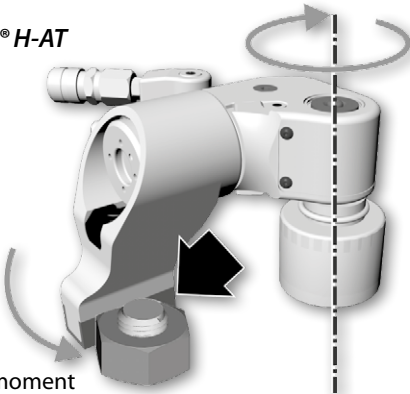

Use High Pressure Quick releasing couplers for quick connection of Torque Wrench to the hose and pump. Make sure that the spring-loaded retaining rings are fully engaged and the safety rings are tightly threaded against the spring-loaded retaining rings to prevent the connectors from disengaging under pressure.

4.2.3 General description tightening/loosening



The following is a general operation manual. The operation manual applies exclusively to the hydraulic power unit being used. The operator must read and understand this operation and maintenance manual before operation or maintenance.

- Set hydraulic power unit in operation according to the operation manual.
- Carry out pressure adjustment at the hydraulic power unit according to torque chart of the *alkitronic® Hydraulic Torque Wrench* (see example page 12 above, Fig. 4).
- Activate the torque tool a couple of times before connecting to bolt/nut to ventilate hoses and the tool, if necessary. Make sure function is faultless.
- Connect the Torque Wrench with the bolt/nut and start the bolting process. The reaction surface (*H-AX* hex link) or the reaction arm (*DMA*) of the Torque Wrench will move against the support point and the bolt/nut will begin to turn.



Observe the safety instructions and danger areas, see item 4.2.1

- Keep pressing the remote control button of the hydraulic pump until the drive of the *alkitronic® H-AT* or *H-AX* stops turning. The pre-set pressure is reached.
- Then press the button on the remote control once or twice until the previously set pressure is reached (recommended to ensure that the applied torque is transferred to the bolt connection and that the Torque Wrench does not just stop at the end stop of the hydraulic piston).
- Check the pressure gauge on the hydraulic unit to ensure that the set pressure has been reached.

4.2.2 Starting procedure hydraulic power unit

Procedures

- when first putting the tool into operation
- when changing Torque Wrenches at the hydraulic unit



DANGER!

Do not exceed the determined maximum nominal pressure or torque of the Torque Wrench, square drive inserts, and other spare parts you are using, when adjusting the hydraulic pressure or the torque.

Non-observance may cause damage to property or personal injury.



CAUTION!

Observe the enclosed data sheets/torque tables of the *alkitronic® Hydraulic Torque Wrenches*.

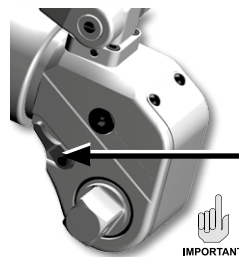

Re-positioning the Torque Wrench to the next bolt connection may not be possible due to the high torsional force.

Apply pressure again (possibly 5 bar more than set). Press the release latch down. Now the ratchet element and the Wrench are released.

Operation and Maintenance Manual

alkitronic® Torque Table (sample *alkitronic® H-AT 5*)



Drehmomenttabelle
Torque table / Tableau de couple

AS 5		AS 9	
bar	Nm	PSI	ft.lf
80	800	1100	800
100	1070	1400	785
120	1200	1700	880
140	1500	2000	1090
160	1700	2300	1260
180	1930	2600	1420
200	2150	2900	1580
220	2360	3200	1750
240	2560	3500	1915
260	2760	3800	2000
280	3010	4100	2245
300	3220	4400	2405
320	3440	4700	2570
340	3650	5000	2735
360	3870	5300	2900
380	4080	5600	3065
400	4300	5900	3230
420	4510	6200	3395
440	4720	6500	3560
460	4940	6800	3720
480	5150	7100	3885
500	5370	7400	4050
520	5590	7700	4215
540	5800	8000	4375
560	6020	8300	4540
580	6230	8600	4710
600	6450	8900	4870
620	6670	9200	5030
640	6880	9500	5195
660	7100	9800	5360
680	7310	10100	5520
700	7520	10400	5690

Fig. 4
alkitronic® H-AT
Shroud with torque
table

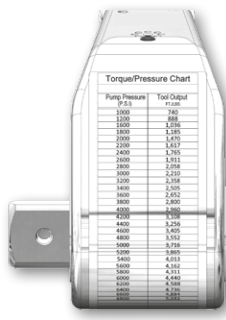

5. Ending or Interrupting the Work

(Also with accessories change)

- Break off tool pressure by turning off the hydraulic power unit to avoid unintended operation.
- Do not lift or carry the *alkitronic® Hydraulic Torque Wrench* by the hoses.
- Remove quick-lock couplings at the hydraulic power unit, when finishing operation.



DANGER!

Within a hydraulic bolting system the tool as well as the hydraulic cords are highly pressurized. Only remove pressure-free hydraulic hoses to avoid personal injury or damage to the tool. Always interrupt air pressure supply at the hydraulic power unit first.



CAUTION!

Leaking oil is hazardous to the environment. Possibly leaking oil must be safely collected and properly disposed of.



IMPORTANT!

Keep all movable parts, bearings, oil connections etc. clean and lubricated.

6. Functional and Operational Tests

6.1 Optical inspection

Check all connections (nipples/couplings) for proper condition.

6.2 Tightness and contamination

- Check all: tool, high-pressure hydraulic hoses, and all connections for integrity and possible replacement or cleaning.
- Contamination in the hydraulic system will cause malfunctions and operating failure.
- Check hydraulic components for tightness. Defective components must be replaced professionally.

6.3 Specialist inspection

- The *alkitronic® Hydraulic Torque Wrench* is an extremely powerful and robust tool. Nevertheless to ensure performance for years regular maintenance of the *alkitronic® Hydraulic Torque Wrenches* is necessary. Maintenance must be performed by authorized personnel according to legal regulations.
- For safety reasons all hydraulic hoses used in regular requirements must be replaced at the latest after five years (additionally max. two years storage). After increased requirements (multiple shifts, short cycle times, hand tools) replace the hoses after two years.



IMPORTANT!

In cases of performance loss, loud gear noises or recognizable heavy damage repair immediately. For repairs, the *alkitronic® Hydraulic Torque Wrench* (in its original package) must be sent to the appropriate *alkitronic® Partner* or directly to alki TECHNIK GmbH.

7. Service / Storage / Maintenance

alki TECHNIK GmbH provides usable spare parts sets for maintenance or replacement by authorized personnel. Parts lists with sectional tool drawings are also available. Please contact your *alkitronic® Partner*.

7.1 Lubrication



IMPORTANT!

Keep all movable parts, sliding surfaces, bearing surfaces, multi-axis swivels etc. clean and lubricated to avoid shortening the life of the tool. Dirt or corrosion affect tool performance adversely. See page 13, Lubrication points Fig. 5.

Recommended lubrication:

Liqui Moly Marine (Liqui Moly Boots Grease)

Maintenance periods:

Upon continuous operation every 20 hours.

Improper lubrication may undermine torque accuracy.

alkitronic® H-AX / H-AT hydraulic torque wrenches

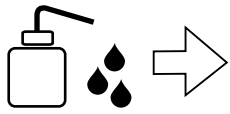

Lubrication points (Fig. 5)
(without dismantling Torque Wrench). First clean and dry the components.

H-AX Hex Link

- (1) Apply grease onto both outer surfaces of drive plate,
- (2) both front surfaces and
- (3) both-sided slotted holes as well as drive pin.

H-AX Drive

- (4) Apply grease onto outer surfaces of piston rod front part
- (5) and slide surfaces of slider

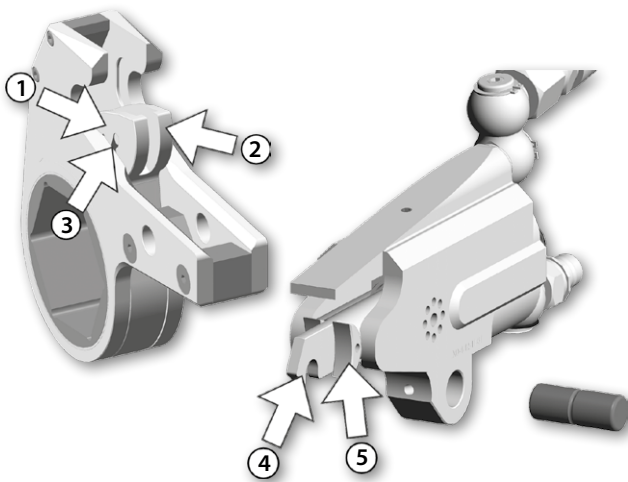

H-AT Torque Wrench

- (6) Preparation:
remove shroud screws and shroud,
- (7) apply grease onto both inner surfaces of housing.

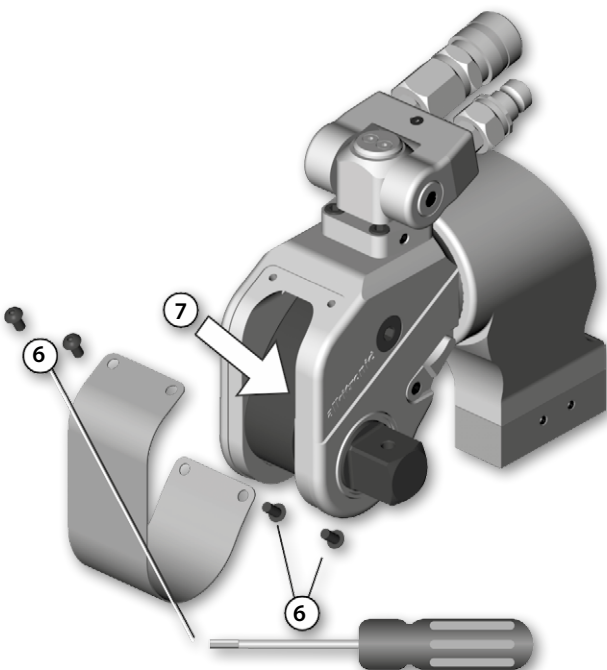

7.2 Storage



Always store the dry, clean *alkitronic® Hydraulic Torque Wrench* in its transportation case or in any lockable box. Moisture leads to oxidation on both housing and interior parts. As a result malfunction and further damages may occur.

For storage, make sure the hydraulic hoses are disconnected and that the ends of the hose lines and the connecting components (couplings/nipples) are plugged with protecting caps.

- Store the hydraulic hoses in a cool, dry, and dust-free location.
- Avoid direct solar and UV radiation, ozonegenerating lighting (i.e. fluorescent sources of light, mercury vapor lamps), and storage temperatures below -10°C.

7.3 Taking out of operation



If the *alkitronic® Hydraulic Torque Wrench* is stored for a long time, store the cleaned tool in a closeable and dry room, out of the reach of children. Moving tool parts are to be protected against oxidation. Additionally note item 7.2, Storage.

7.4 Maintenance intervals



The Torque Wrench must be submitted at least once a year for inspection. After high strain/loads/hours of operation, wear or leakage, calibration and servicing must be carried out after shorter periods.

Lubrication - also see page 12, item 7.1.

8. Technical Notes

To avoid faulty bolted joints or motor damage, observe the following:

- Oil temperature must not exceed 65°C.
- Regularly check oil level and oil condition on pump reservoir.
- Regularly check the accuracy of the gauge with a testing manometer.

9. Appendix

- Trouble Shooting, page 14
- Technical Data, page 15
- Torque Chart (Attachment)

Materials and specifications are subject to change without notice.

©alkitechnik / GBA AT-H-AX / 2/28-06-22-4Pdesign

Operation and Maintenance Manual

Trouble Shooting

Problem	Probable Cause	Solution
Tool does not rotate	<ol style="list-style-type: none"> 1. Connections are not attached properly 2. Damaged joint couplings 3. Damaged hose connection 4. Inspect the hydraulic power unit for contamination or foreign particles 5. H-AT drive latch or ratchet teeth heavily contaminated 6. Damaged H-AT ratchet or drive latch 	<ol style="list-style-type: none"> 1. Coupling/nipple must be engaged completely 2. Replace joint couplings 3. Replace hose couplings 4. Clean or remove hydraulic power unit 5. Clean or remove 6. Replace
Tool will not build pressure	<ol style="list-style-type: none"> 1. Cylinder does not retract 2. Motor coupling of hydraulic pump is damaged 3. Defective cylinder sealing 4. Defective sealing at the hose coupling unit 	<ol style="list-style-type: none"> 1. Check connections 2. Replace couplings 3. Replace sealings 4. Replace sealings
Tool is leaking oil	<ol style="list-style-type: none"> 1. Damaged O-seals 2. Defective joint couplings 	<ol style="list-style-type: none"> 1. Replace sealings 2. Replace joint couplings
Tool is rotating; piston must have been retracted	<ol style="list-style-type: none"> 1. Connections improperly installed 	<ol style="list-style-type: none"> 1. Make sure, advance or return couplings are installed correctly (Page 10, Item 4.1)
Tool is rotating, while piston retracts	<ol style="list-style-type: none"> 1. Defective drive plug 	<ol style="list-style-type: none"> 1. Replace drive plug
Tool does not rotate sequentially	<ol style="list-style-type: none"> 1. Loose or defective connection 2. Damaged joint couplings 3. Operator initiated next stroke, before oil had flown back into the tank. Piston could not retract to starting position 4. Broken drive plug 	<ol style="list-style-type: none"> 1. Coupling/nipple must be connected properly or replaced 2. Replace joint couplings 3. Wait until oil flows back into the tank of the pump and the piston has reached starting position 4. Replace
Tool pops off nut	<ol style="list-style-type: none"> 1. Improper reaction support 	<ol style="list-style-type: none"> 1. Always react in plane with the support <i>DMA</i> and the square drive inserts (see Page 7, Item 3.3 / Page 8, Pkt. 3.5.1 - Support of reaction moment). Consult your alkitronic® Partner to see if a custom reaction or another alkitronic® Hydraulic Torque Wrench is better suited for the particular application

alkitronic® H-AX / H-AT hydraulic torque wrenches

Technical Data

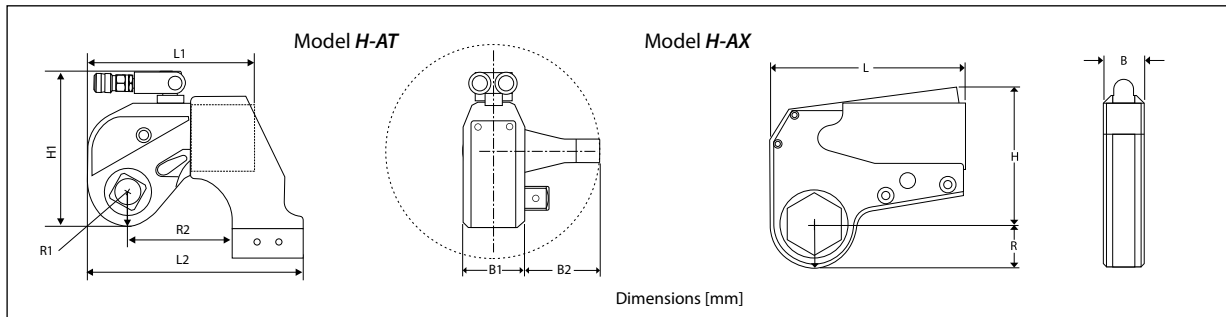

Models alkitronic® H-AT

Type		H-AT 1	H-AT 2	H-AT 3	H-AT 5	H-AT 8	H-AT 10	H-AT 20	H-AT 25	H-AT 35	H-AT 50
Torque range (approx.)	Nm	110-1120	180-1840	450-4510	750-7530	1080-10780	1550-15520	2660-26660	3470-34730	4860-48600	7200-72000
	ft.lbs	80-826	133-1357	332-3326	553-5554	797-7951	1143-11447	1962-19663	2559-25615	3585-35845	5310-53100
Square drive size		3/4"	3/4"	1"	1 1/2"	1 1/2"	1 1/2"	2 1/2"	2 1/2"	2 1/2"	2 1/2"
Height	H2 mm	108.1	131	176.5	199	217	232	270	297	332	341
Length	L1 mm	110.8	144.5	178	210.5	222	245.5	307.5	323	372.5	400
Length	L2 mm	139.3	173	229	270.5	293	317.5	383.5	401	496.5	516
Radius	R mm	20.5	26	34	39	47	51	59	66	77	81
Radius	R2 mm	68.3	85	114	137	153	154	186	199	214	259
Width	B1 mm	42	50	68	80	90	100	120	137	153	160
Width	B2 mm	54	66.5	89.5	100	120	128	153	159.5	167	178
Weight (approx.)	kg mm	1.8	2.5	5	8	11	15	26.5	35	50	87

To reproduce the specified torque exactly, pressure of max. 700 bar is needed. Repeatability $\pm 3\%$. For a fast, safe and reliable operation of the hydraulic wrenches we recommend our alkitronic® NOVA or VELOX hydraulic pumps (700 bar pressure, can be used worldwide in all mains grids 100-253 V / 45-66 Hz).

Models alkitronic® H-AX

Type		H-AX 1	H-AX 2	H-AX 4	H-AX 8	H-AX 16	H-AX 32 ***
Torque range (approx.) *	Nm	60-770	260-2600	540-5400	1150-11900	2150-22900	4450-49000
	ft.lbs	45-560	192-1928	395-3950	830-8630	1560-16600	3220-35650
Hexagon **	SW mm	14-32	27-55	36-70	55-95	80-115	95-145
Width	B mm	24	38	47	58	70	92
Length	L mm	111	167	203	253	330	390
Height	H mm	83	103	144	180	194	278
Weight	kg	0.5	1.6	3.5	6.6	13	18

Ask us about: **) other A/F sizes ***) models with larger torque range

Models alkitronic® H-AX Link

Type H-AX 1-	A/F	SW 14	SW 19	SW 22	SW 24	SW 27	SW 30	SW 32				
Radius (approx.)	R mm	19	19	23	23	23	25	25				
Type H-AX 2-	A/F	SW 27	SW 30	SW 32	SW 36	SW 41	SW 46	SW 50	SW 55			
Radius (approx.)	R mm	26	28	28	31	33	36	39	42			
Type H-AX 4-	A/F	SW 36	SW 41	SW 46	SW 50	SW 55	SW 60	SW 65	SW 70			
Radius (approx.)	R mm	34	34	37	41	44	46	49	52			
Type H-AX 8-	A/F	SW 55	SW 60	SW 65	SW 70	SW 75	SW 80	SW 85	SW 90	SW 95		
Radius (approx.)	R mm	46	49	52	55	58	60	65	67	79		
Type H-AX 16-	A/F	SW 80	SW 85	SW 90	SW 95	SW 100	SW 105	SW 110	SW 115			
Radius (approx.)	R mm	63	67	69	75	75	78	87	87			
Type H-AX 32-	A/F	SW 95	SW 100	SW 105	SW 110	SW 115	SW 120	SW 125	SW 130	SW 135	SW 140	SW 145
Radius (approx.)	R mm	82	82	88	94	94	100	100	100	104	109	109

*) When loosening a bolted connection, up to 20% higher torque may be required (loosening torque). We will gladly advise you in detail.

YOUR PLUS FOR MORE PERFORMANCE

Increased quality

Premium production
Highest quality materials
Long product life cycles
Experience in bolting technology since 1984
Made in Germany – international patents

Increased precision

Precise, customer-specific torques
High repeatability
Reliability in permanent operation
Documentation of tightening results
Automatic shut-off

Increased productivity

Quicker tightening without reworking
No environmentally caused failures (IP54, ATEX)
High work safety
Easy to use: clear, simple instructions
Low maintenance and cost efficient

Better service

Technical advice on site
Training offers
Manufacturer's calibration and certification
Lifecycle support
Spare part and repair service

alki TECHNIK GmbH

Development, Production and Distribution of Bolting Systems

Unterlettenweg 4 – 85051 Ingolstadt/Germany – fon +49 841 97499-0 – fax +49 841 97499-90
info@alkitronic.com – www.alkitronic.com

EXTRACT FROM OUR PRODUCT RANGE



alkitronic X^E-SERIES

THE ELECTRICS

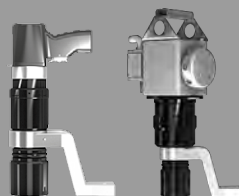

alkitronic X^P-SERIES

THE PNEUMATICS

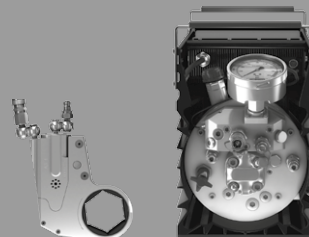

alkitronic X^H-SERIES

THE HYDRAULICS



alkitronic X^M-SERIES

THE MANUALS